

Valce k nožovým posúvačom

Valce k nožovým posúvačom

Všeobecný opis	
Priemer piestu	Ø80 - Ø100 - Ø125 - Ø160 - Ø200 - Ø250 - Ø320 mm
Štandardný zdvih	25 - 50 - 80 - 100 - 125 - 160 - 200 - 250 - 320 - 400 - 500 - 600 - 700 - 800 - 900 - 1000 mm
Pracovné médium	stlačený vzduch
Pracovný tlak	1 ... 10 bar
Teplota okolia	-20°C ... +80°C
Pri teplotách pod 0°C je potrebné používať vhodne pripravený, suchý stlačený vzduch.	

L	A	Z	80	/	200
			PRIEMER		ZDVIH
			80		25
			100		50
			125		80
			160		100
			200		125
			250		160
			320		200
					250
					320
					400
					500
					600
					700
					800
					900
					1000

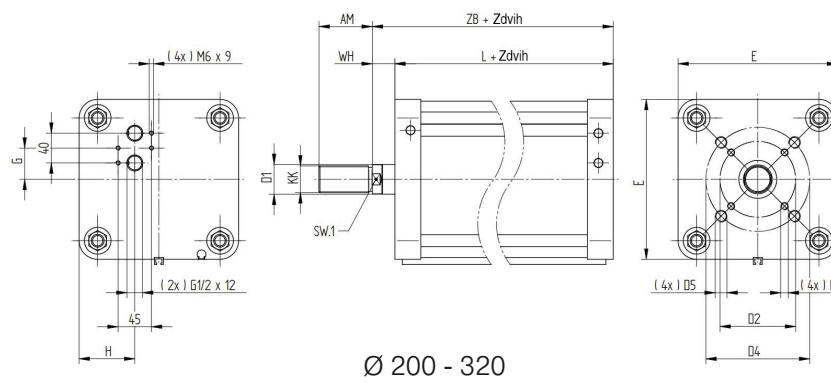
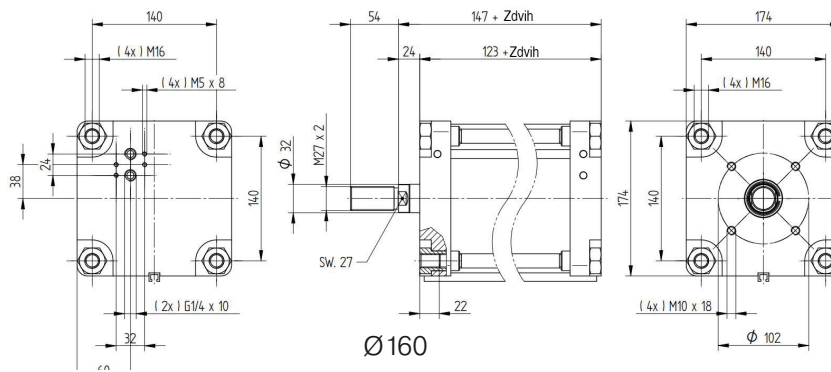
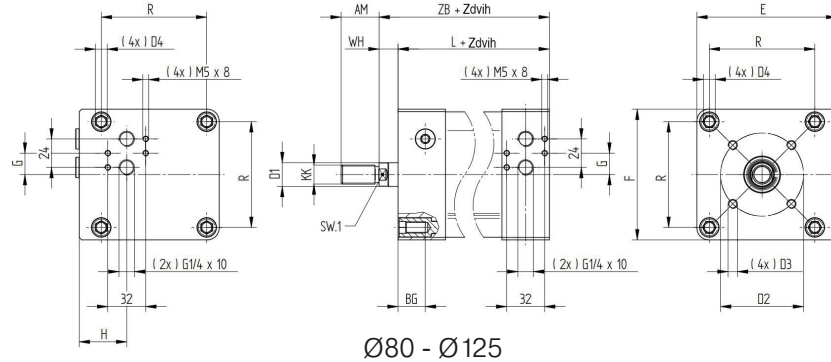
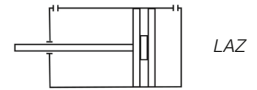
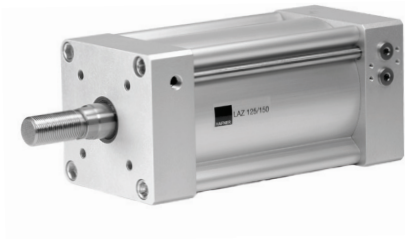

Ø [mm]	AM	D1	KK	SW.1	D2	D3	D4	BG	R	D5	E	F	G	H	WH	L	ZB
Ø 80	32	Ø20	M16x1,5	17	Ø70	M8x15	M10	22	72	-	100	90	8	35	16	114	130
Ø 100	32	Ø20	M16x1,5	17	Ø70	M8x15	M10	22	89	-	118	110	18	40	16	118	134
Ø 125	54	Ø32	M27x2	27	Ø102	M10x18	M12	26	110	-	140	134	28	45	24	138	162
Ø 200	72	Ø40	M36x2	36	Ø102	M10x20	Ø140	-	-	M16x25	215	-	-	75	30	123	153
Ø 250	72	Ø40	M36x2	36	Ø102	M10x20	Ø140	-	-	M16x25	265	-	-	80	30	138	168
Ø 320	72	Ø40	M36x2	36	Ø102	M10x20	Ø140	-	-	M16x25	340	-	-	100	30	135	168