



aerospace
 climate control
 electromechanical
filtration
 fluid & gas handling
 hydraulics
 pneumatics
 process control



⚠ WARNING: The products described in this catalog can expose you to chemicals including Diisononyl phthalate, Carbon black, which are known to the State of California to cause cancer. For more information go to www.P65Warnings.ca.gov.

Fuel Filtration Systems

Products and Custom Solutions



ENGINEERING YOUR SUCCESS.

About Racor

Parker Hannifin Corporation, global leader in motion and control technologies, delivers an unmatched breadth of engineered products and solutions. Our commitment to our customers is backed by the strength that comes from over 100 years of knowledge and experience.

About Racor.

For over fifty years Racor has been one brand of fuel filtration systems that has earned the confidence and respect of engine and equipment builders, owners and operators around the world.

Leading edge technology and continuous innovation are designed into every system, and genuine Aquabloc® Synergy filters have set the global standard.

In every configuration, at every flow rate, and in any operating environment, Racor is the most trusted name in engine protection.

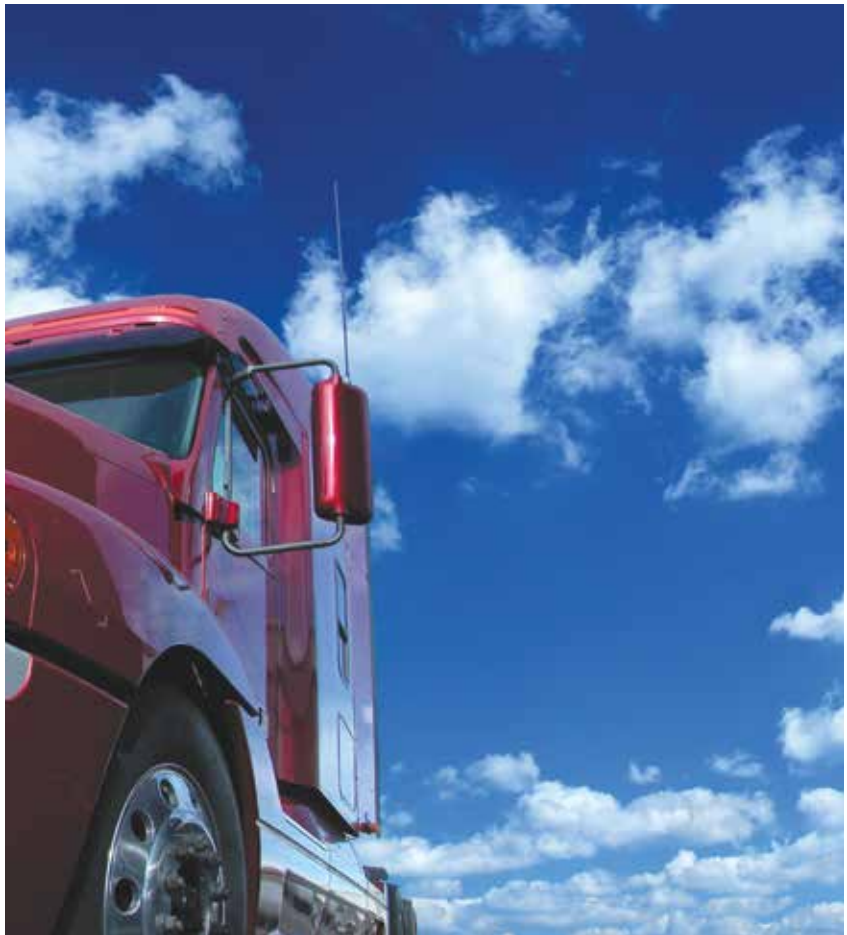

A World of Fuel Challenges

Fuel contamination, either in the form of dirt or water, will find its way into your fuel system no matter how careful you are. With modern engines injecting fuel at pressures up to 30,000 PSI, and injector tolerance being measured in microns, even a small amount of dirt or water corrosion can start problems. Water or particulates can cause microscopic surface damage that is then focused on by the high-pressure fuel flow, which causes wear that will eventually lead to reduced efficiency and complete breakdown. With this in mind, managing fuel delivery and system cleanliness through proper filtration becomes an absolute imperative for economical engine operation.



For marine applications, please see Racor brochure #RSL7501.

Racor Solutions For Your Future

Racor has quality-certified manufacturing, engineering and distribution in place around the world, so no matter where you are you can rely on Racor to solve tough filtration problems from the refinery to the engine. Over the years, Racor has kept pace with the increasing demands of fuel filtration, from tough engine requirements for ever-finer particle-removal efficiencies and longer life, to the effective processing of ULSD and biodiesel.



The heart of these advances is in Racor's proprietary engineered filter media families. Our selection of Aquabloc® Synergy medias is known worldwide for its combination of high efficiency, long life, and unsurpassed water-removal performance; meeting and exceeding the challenges of today's diesel engine requirements in all markets and environments.

Using Aquabloc® Synergy media, Racor Engineering develops innovative solutions to become integral components in complex engine fuel systems designed by the world's leading OEM engine manufacturers. Racor develops new solutions using ISO, SAE, JIS and other world-recognized testing procedures to conform to any specifications required by our OEM customers. Racor performs on-engine, on-vehicle and laboratory diesel system testing to further the advancement of diesel filtration for today and into the future. All diesel engine users benefit from this ongoing demand for the latest technology in fuel filtration and fuel system designs.



The future of the diesel engine relies on increasingly stringent exhaust emission requirements, while the quality of diesel fuel worldwide is never assured. New diesel engines require extraordinary fuel cleanliness and freedom from water contamination to meet these requirements. Ultra low sulfur diesel (ULSD) and the use of biodiesel pose ongoing filtration challenges due to their tendency to dissolve existing deposits, absorb water, and support the growth of bacteria. Even cold weather operation is compromised by these fuels; leading to filter clogging and unscheduled downtime.



Cost-Effective Visual Inspection

See-thru collection bowls allow a water-in-fuel condition to be immediately visible.

Environmentally Friendly

Engineered polymer bowls are reusable, impact-resistant and very durable. When it's time for service, only the filter element is replaced - the see-thru bowl and drain valve assembly are reused. The long life cycle of the bowl saves money and reduces the environmental impact through disposal of less material.

Easy Upgrades

See-thru bowls provide connection ports for upgrades that enhance engine performance and reliability. Powerful in-bowl heaters can be added to improve operation in colder climates and electronic sensors alert the operator to drain water in the bowl.

Corrosion-Free Construction

Advanced polymer technology means bowls will resist deterioration from water collection, alcohol-blended fuels, exposure to harsh additives and UV light.

High quality gaskets and O-rings for consistent, sure seals.

Die cast aluminum mounting heads with multiple ports make installation as easy as adding options.

Durable hand primer pumps are integrated into mounting heads.

The heart of every Racor filter is the engineered filter media. Aquabloc® Synergy is known around the world for its combination of high efficiency, long life and unsurpassed water-removal performance.

Polymer bowls are highly durable. They won't discolor from exposure to alcohol, additives or UV light - a see-thru that stays see-thru. A die cast aluminum bowl is available for most models.

Water sensor and vacuum indicators to signal service are valuable options available for most models.

Positive seal self-venting drain eliminates leaks and expedites service.





Model 460R

445 - 460 - 490

A powerful, integral primer pump makes service quick and easy

The standard equipment primer pump tops the list of extensive options that allow bus fleets, truck fleets, RV owners and others to tailor a filter/separator system specifically to their operating requirements. These options include a choice of a three-micron rating for the Aquabloc® Synergy filter element, 200-watt in-bowl resistance heater, water sensor and flow rates up to 120 gph.



Model 660R

645 - 660 - 690

Maximize engine protection with a low-profile, easy-to-fit filtration system

With all the features of the 400 Series, the 600 Series offers engine owners an economical system for applications where an integral primer pump is not needed. Flow rates up to 120 gph, in-bowl heater and water sensor are all available options.



MEDIUM FLOW

MODEL ¹	445R2 /10 /30	460R2 /10 /30	490R2 /10 /30	645R2 /10 /30	660R2 /10 /30	690R2 /10 /30
Maximum Flow Rate	45 gph / 170 lph	60 gph / 227 lph	90 gph / 341 lph	45 gph / 170 lph	60 gph / 227 lph	90 gph / 341 lph
Gasoline or Diesel	Diesel	Diesel	Diesel	Both	Both	Both
Vacuum Installation	Yes	Yes	Yes	Yes	Yes	Yes
Pressure Installation	Yes	Yes	Yes	Yes	Yes	Yes
Maximum PSI ² / kPa	30 psi / 207 kPa	30 psi / 207 kPa	30 psi / 207 kPa	30 psi / 207 kPa	30 psi / 207 kPa	30 psi / 207 kPa
Clean Pressure	0.17 psi	0.39 psi	0.95 psi	0.01 psi	0.05 psi	0.29 psi
Drop PSI / kPa	1.2 kPa	2.7 kPa	6.5 kPa	0.07 kPa	0.34 kPa	2.0 kPa
No. of Ports	4	4	4	7	7	7
Port Size	3/8" NPT / 16 mm	3/8" NPT / 16 mm	3/8" NPT / 16 mm	3/8" NPT / 16 mm	3/8" NPT / 16 mm	3/8" NPT / 16 mm
Integral Primer Pump ³	Yes	Yes	Yes	No	No	No
Replacement Element No. ⁴	R45	R60	R90	R45	R60	R90
Bowl / See-Thru	Yes	Yes	Yes	Yes	Yes	Yes
Bowl / Metal	No	No	No	No	No	No
Drain Type	Self-Vent	Self-Vent	Self-Vent	Self-Vent	Self-Vent	Self-Vent
Water Sensor Option ⁵	Yes	Yes	Yes	Yes	Yes	Yes
Electric Heater Option ⁵ (12V/24V)	Yes	Yes	Yes	Yes	Yes	Yes
Height	9.3 / 236 mm	11 / 279 mm	11.8 / 300 mm	8.46 / 215 mm	10.2 / 259 mm	11.2 / 284 mm
Width	4.5 / 114 mm	4.5 / 114 mm	4.5 / 114 mm	4.5 / 114 mm	4.5 / 114 mm	4.5 / 114 mm
Depth	4.8 / 121 mm	4.8 / 121 mm	4.8 / 121 mm	4.5 / 114 mm	4.5 / 114 mm	4.5 / 114 mm
Weight	2.5 lbs / 1.1 Kg	2.7 lbs / 1.3 Kg	2.9 lbs / 1.4 Kg	2.35 lbs / 1.07 Kg	2.58 lbs / 1.17 Kg	2.65 lbs / 1.2 Kg

Notes:

- (1) Assemblies can be specified as 2 for 2 micron, 10 for 10 micron, or 30 for 30 micron. Example part number: 445R2.
- (2) Pressure installations are applicable up to the maximum PSI/ kPa shown.
- (3) Models with integral primer pumps are not recommended for gasoline applications.
- (4) Replacement element micron rating can be specified as "S" for 2 micron, "T" for 10 micron, or "P" for 30 micron. Example P/N: R45S.
- (5) Not for use with gasoline applications.

110A - 120A - 140



Model 120AT

Maximum protection in minimum space

The 110A is designed for fuel-injected gasoline engines with high working pressures and also can be used on diesel engines. A metal housing is standard. Other models in the 100 Series, the 120A and 140, offer reliable protection for smaller diesel and gasoline engines used in generator sets, pressure washers and other equipment. Their compact size fits tight mounting locations and multiple ports offer installation flexibility.



Model 230R2

215 - 230 - 245

Improved for greater versatility

The 215, 230 and 245 filter/separators come standard with an integral priming pump and a see-thru contaminant bowl, which can operate in applications up to 30 psi. Another design upgrade is the optional 200-watt in-bowl heater for colder operating conditions. Applications include light-duty and medium-duty trucks and vehicles, construction, agricultural and other diesel-powered equipment.



LOW FLOW

MODEL	110A (10 micron)	120AS / T / P	140R (10 micron)	215R2 / 10 / 30	230R2 / 10 / 30	245R2 / 10 / 30
Maximum Flow Rate	15 gph / 57 lph Diesel 35 gph / 132 lph Gas	15 gph / 57 lph	15 gph / 57 lph	15 gph / 57 lph	30 gph / 114 lph	45 gph / 170 lph
Gasoline or Diesel ¹	Both	Both	Both	Diesel	Diesel	Diesel
Vacuum Installation	Yes	Yes	Yes	Yes	Yes	Yes
Pressure Installation	Yes	Yes	Yes	Yes	Yes	Yes
Maximum PSI ² / kPa	100 psi / 690 kPa	7 psi / 48 kPa	7 psi / 48 kPa	30 psi / 207 kPa	30 psi / 207 kPa	30 psi / 207 kPa
Clean Pressure	0.15 psi	0.15 psi	0.01 psi	0.12 psi	0.31 psi	0.61 psi
Drop PSI/kPa	1.03 kPa	1.03 kPa	0.07 kPa	0.83 kPa	2.14 kPa	4.21 kPa
No. of Ports	4	4	2	3	3	3
Port Size	1/4" NPT/ M14 x 1.5	1/4" NPT/ M14 x 1.5	1/4" NPT/ M14 x 1.5	1/4" NPT/ M14 x 1.5	1/4" NPT/ M14 x 1.5	1/4" NPT/ M14 x 1.5
Integral Primer Pump ³	No	No	No	Yes	Yes	Yes
Replacement Element No. ⁴	R11	R12	R12	R15	R20	R25
Bowl/See-Thru	No	Yes	Yes	Yes	Yes	Yes
Bowl/Metal ¹	STD	Yes	Yes	Yes	Yes	Yes
Drain Type	Positive Seal	Positive Seal	Positive Seal	Positive Seal	Positive Seal	Positive Seal
Water Sensor Option ⁵	Yes	Yes	Yes	Yes	Yes	Yes
Electric Heater Option ⁵ (12V/24V)	No	No	No	Yes	Yes	Yes
Height	6" / 152 mm	6.5" / 166 mm	6" / 152 mm	8.3" / 211 mm	9" / 229 mm	10.5" / 267 mm
Width	3.2" / 81 mm	3.2" / 81 mm	3.2" / 81 mm	4" / 102 mm	4" / 102 mm	4" / 102 mm
Depth	3.2" / 81 mm	3.2" / 81 mm	3.2" / 81 mm	4" / 102 mm	4" / 102 mm	4" / 102 mm
Weight	1.3 lbs / 0.59 Kg	1.1 lbs / 0.50 Kg	1.1 lbs / 0.50 Kg	1.8 lbs / 0.80 Kg	2 lbs / 0.90 Kg	2.2 lbs / 1.0 Kg

- Notes: (1) Metal bowls should be used for gasoline installations.
 (2) Pressure installations are applicable up to the maximum PSI/kPa shown.
 (3) Models with integral primer pumps are not recommended for gasoline applications.
 (4) Replacement element micron rating can be specified as "S" for 2 micron, "T" for 10 micron, or "P" for 30 micron, except for R11.
 (5) Not for use with gasoline applications.

Racor Quality in One Easy Spin

- High-capacity, on-engine primary or secondary filtration
- Fits most existing mounting heads
- See-thru bowl with water sensor option
- Mounting heads available, contact Racor or your distributor



Model 3250R

4125 - 6125 - 3150 - 3250

High flow applications need not suffer with high maintenance... and Racor offers a range of ultra-high capacity, highly efficient fuel filter/water separators that also deliver spin-on convenience. As you'd expect, Aquabloc® Synergy media is standard and all units provide flexibility in options to customize and meet specific operating conditions.



H I G H F L O W

MODEL	4125R2 /10 /30	6125R2 /10 /30	3150R (10 mic)	3250R (10 mic) /2 /30
Maximum Flow Rate	120 gph / 454 lph	120 gph / 454 lph	150 gph / 570 lph	250 gph / 946 lph
Gasoline or Diesel ¹	Diesel	Both	Diesel	Diesel
Vacuum Installation	Yes	Yes	Yes	Yes
Pressure Installation	Yes	Yes	Yes	Yes
Maximum PSI ² /kPa	15 psi / 103 kPa	15 psi / 103 kPa	7psi / 50 kPa	7 psi / 50 kPa
Clean Pressure Drop PSI	0.85 psi	0.35 psi	0.68 psi	1 psi
No. of Ports	4	7	2	2
Port Size	3/4" SAE / 18 mm	3/8 NPT	0.875" X 14 SAE	0.875" X 14 SAE
Integral Primer Pump ³	Yes	No	No	No
Replacement Element No. ⁴	R125S (2 mic) R125T (10 mic) R125P (30 mic)	R125S (2 mic) R125T (10 mic) R125P (30 mic)	S3238 (10 mic) S3238P (30 mic)	S3207T (10 mic) S3207S (2 mic) S3207P (30 mic)
Bowl / See-Thru	Yes	Yes	Yes	Yes
Bowl / Metal ¹	No	No	Yes	Yes
Drain Type	Self-Vent	Self-Vent	Self-Vent	Self-Vent
Water Sensor Option ⁵	Yes	Yes	Yes	Yes
Electric Heater Option ⁵ (12V/24V)	Yes	Yes	Yes	Yes
Height	15 / 381 mm	14.12 / 359 mm	13.6 / 345 mm	17.25 / 438 mm
Width	4.5 / 114 mm	4.5 / 114 mm	5 / 127 mm	5 / 127 mm
Depth	4.8 / 121 mm	4.5 / 114 mm	5.5 / 140 mm	5.5 / 140 mm
Weight	3.9 lbs / 1.8 Kg	3.9 lbs / 1.8 Kg	3.6 lbs / 1.6 Kg	4.6 lbs / 2.08 Kg

- Notes: (1) Metal bowls should be used for gasoline installations.
 (2) Pressure installations are applicable up to the maximum PSI/ kPa shown.
 (3) Models with integral primer pumps are not recommended for gasoline applications.
 (4) Replacement element micron rating can be specified as "S" for 2 micron, "T" for 10 micron, or "P" for 30 micron.
 (5) Not for use with gasoline applications.



Racor filter materials and seals are compatible with ultra-low sulphur diesel (ULSD) fuel and B2 to B20 Biodiesel.

The Racor 700 Series is equipped with state-of-the-art fuel pumps with either brush or brushless DC motors. DC motor makes this product the most reliable filter and pump assembly on the market. The brushless pump assembly is ideal for tough on-engine applications. For off-engine mounting, brushed pumps are a more economical alternative.

This complete fuel management system isolates contaminants present in diesel fuels and traps them prior to reaching the fuel injection system, protecting against costly and premature failure.



700 Series Integrated Filter/Separators



Model 790R30

The heart of every Racor filter is the engineered filter media. Aquabloc® Synergy is known around the world for its combination of high efficiency, long life and unsurpassed water removal performance.

Bowls are highly durable. They won't discolor from exposure to alcohol, additives or UV light.

Water sensor and vacuum gauges to signal service are valuable options available for most models.

Positive seal self-venting drain.

MODEL	745R30	760R30	790R30 ¹	7125R10 ¹ (10 Micron) 7125R30 ¹ (30 Micron)
Maximum Flow Rate	45 gph / 170 lph	60 gph / 227 lph	90 gph / 341 lph	120 gph / 454 lph
Gasoline or Diesel	Diesel	Diesel	Diesel	Diesel
Replacement Element	R45P	R60P	R90P	R125T (10 Micron) R125P (30 Micron)
Clean Pressure Drop	0.25 psi / 1.7 kPa	0.25 psi / 1.7 kPa	0.25 psi / 1.7 kPa	0.25 psi / 1.7 kPa
Port Size	3/8" NPT	3/8" NPT	3/8" NPT	3/8" NPT
Water Sensor Option	Yes	Yes	Yes	Yes
Height	10.8 / 25.7 cm	11.8 / 28.4 cm	12.8 / 31.2 cm	15.8 / 40.1 cm
Width	4.3 / 11.0 cm	4.3 / 11.0 cm	4.3 / 11.0 cm	4.3 / 11.0 cm
Depth	6.5 / 16.5 cm	6.5 / 16.5 cm	6.5 / 16.5 cm	6.5 / 16.5 cm

¹The 700 Series comes in standard with a 12 volt brushed pump assembly. To order the 24 volt brushless pump assembly, insert 24 at the end of the 790 or 7125 part numbers. (example:790R3024)

For additional information about Racor Filter/ Separator Pump Systems, request brochure #7683.

Fuel Conditioning Module



Durable, 12 vdc roller-cell electric fuel pump offers the benefit of an electric, on-demand, priming pump.

A fuel filter/water separator and primer pump in one unit.

High-performance Aquabloc® Synergy cartridge-style filter media is environmentally friendly and incinerable.



Polish, Prime, Deliver

The P Series Diesel Fuel Conditioning Module was developed for applications on the vacuum side of any diesel engine fuel injection system.

P Series assemblies are available in three sizes and all feature 3/8" NPT fuel ports.

This innovative and modular fuel filter/water separator incorporates low-pressure fuel system components into a single package.

It can act as a reprimer or supply a continuous flow of clean, dry fuel to the fuel system.

Specifications	P3	P4	P5
Maximum Flow Rate	30 GPH (114 LPH)	40 GPH (151 LPH)	50 GPH (189 LPH)
Clean Pressure Drop	0.4 PSI (0.03 bar)	0.5 PSI (0.03 bar)	0.8 PSI (0.06 bar)
Max. Pump Output (at 14 volts)	40 GPH (151 LPH)	40 GPH (151 LPH)	40 GPH (151 LPH)
Standard Fuel Port Size (SAE J476)	3/8"-18 NPT	3/8"-18 NPT	3/8"-18 NPT
Total Number of Ports Available	2	2	2
Fuel Inlets	1	1	1
Fuel Outlets	1	1	1
Replacement Filter			
2 micron	R58060-02	R58095-2	R58039-2
10 micron	R58060-10	R58095-10	R58039-10
30 micron	R58060-30	R58095-30	R58039-30
Minimum Service Clearance	2.5 in. (6.4 cm)	2.5 in. (6.4 cm)	2.5 in. (6.4 cm)
Height	7.7 in. (19.6 cm)	9.0 in. (22.9 cm)	11.5 in. (29.2 cm)
Depth	5.2 in. (13.2 cm)	5.2 in. (13.2 cm)	5.2 in. (13.2 cm)
Width	4.8 in. (12.2 cm)	4.8 in. (12.2 cm)	4.8 in. (12.2 cm)
Weight (dry - approx.)	3.4 lbs (1.5 kg)	3.8 lbs (1.7 kg)	4.2 lbs (1.9 kg)
Maximum Pump Outlet Pressure	10 PSI (0.7 bar)	10 PSI (0.7 bar)	10 PSI (0.7 bar)
Features			
Water Sensor	Standard	N/A	Standard
Heater ¹	Standard	Standard	Standard
Pressure Regulator (10 PSI)	Standard	Standard	Standard

Vacuum installations only. ¹ Not for use with gasoline applications.

How To Order (The example below illustrates how part numbers are constructed).

P4	2	10	N	H
Specify Model P3 (for 30 GPH) P4 (for 40 GPH) P5 (for 50 GPH)	Specifies a 12 vdc pump.	Specify micron rating: 02, 10, or 30	Specifies 3/8" NPT ports.	Specifies a 12 vdc 150 watt heater.



The high-grade aluminum components and powdercoat paints mean that corrosion is never a worry.

A durable single bolt mounting bracket doubles resistance to vibration fatigue.

Aquabloc® Synergy media sheds water and keeps engines waterproof, rustproof and dirtproof.

300-watt heaters start you in the cold. Thermostats are standard to meet the requirements of today's electronic engines.

Polymer bowl withstands impact and temperature extremes.

Self-venting drain. A single twist makes draining clean, fast and easy.

With an Aquabloc Synergy replacement element, you get a complete kit with all the seals you need.

Aquabloc Synergy media is a blend of high-grade cellulose compounded with resins and a special chemical treatment.

Aquabloc Synergy elements filter harmful tiny, particles of dirt and algae from fuel. Aquabloc Synergy elements are rustproof – with polymer end caps that won't ever corrode.

The First Name In Fuel Filtration.

Every engine runs better with a system that cleans fuel, removes water, heats fuel and senses when it's time for service. The system is the Racor Turbine Series and it's the most complete, most efficient, most reliable high-capacity engine protection you can install. A system that protects your investment in engines and fuel.

For marine rated filters, see brochure #7501.

Primer pump kit shown installed.
Order RKP1912 (12 volt) or RKP1924 (24 volt).

End caps are color-coded for easy identification and application – red for 30 micron primary filtration, blue for 10 micron primary or secondary, and brown for 2 micron secondary/final filtration.

Use original Racor filter elements to ensure premium performance.

An integral bail handle makes changeouts easy.

Our toll-free phone number is shown on the end cap. It puts you in touch with Racor's technical service staff who can answer any availability, application, or service question.



The Inside Story

1 As fuel enters, it moves past the internal check valve, then through the turbine centrifuge where it flows in a spiraling direction, spinning off large particulates and water droplets. Being heavier than fuel, the large particulates and water droplets fall to the bottom of the bowl.

2 Smaller water droplets bead-up along and on the sides of the internal components and on the surface of the Aquabloc® Synergy filter. When large enough, they too fall into the high-capacity bowl to be drained as needed.

3 Aquabloc Synergy filter repels any remaining water droplets while stopping and trapping fine rust and dirt particles. Aquabloc® Synergy filters are waterproof, so they remain effective longer, saving you money.

T-Handle Vacuum Indicator Kit For Turbine Series Assemblies

T-Handle vacuum gauge indicators, monitor filter condition as the filter slowly becomes clogged with contaminants. As the filter gets dirty, restriction increases and less fuel is delivered to the engine causing the engine to lose power and eventually stall. By installing a vacuum indicator in your fuel system, visual monitoring of filter condition is possible at a glance, increasing fuel system troubleshooting efficiency, eliminating guess work, and lengthening filter changeout intervals.



RK19671

This restriction indicator kit fits Turbine Series Fuel Filter/Water Separator assemblies and installs in one easy spin. Fits 500 models built after year 2002 and all 900/1000 models.

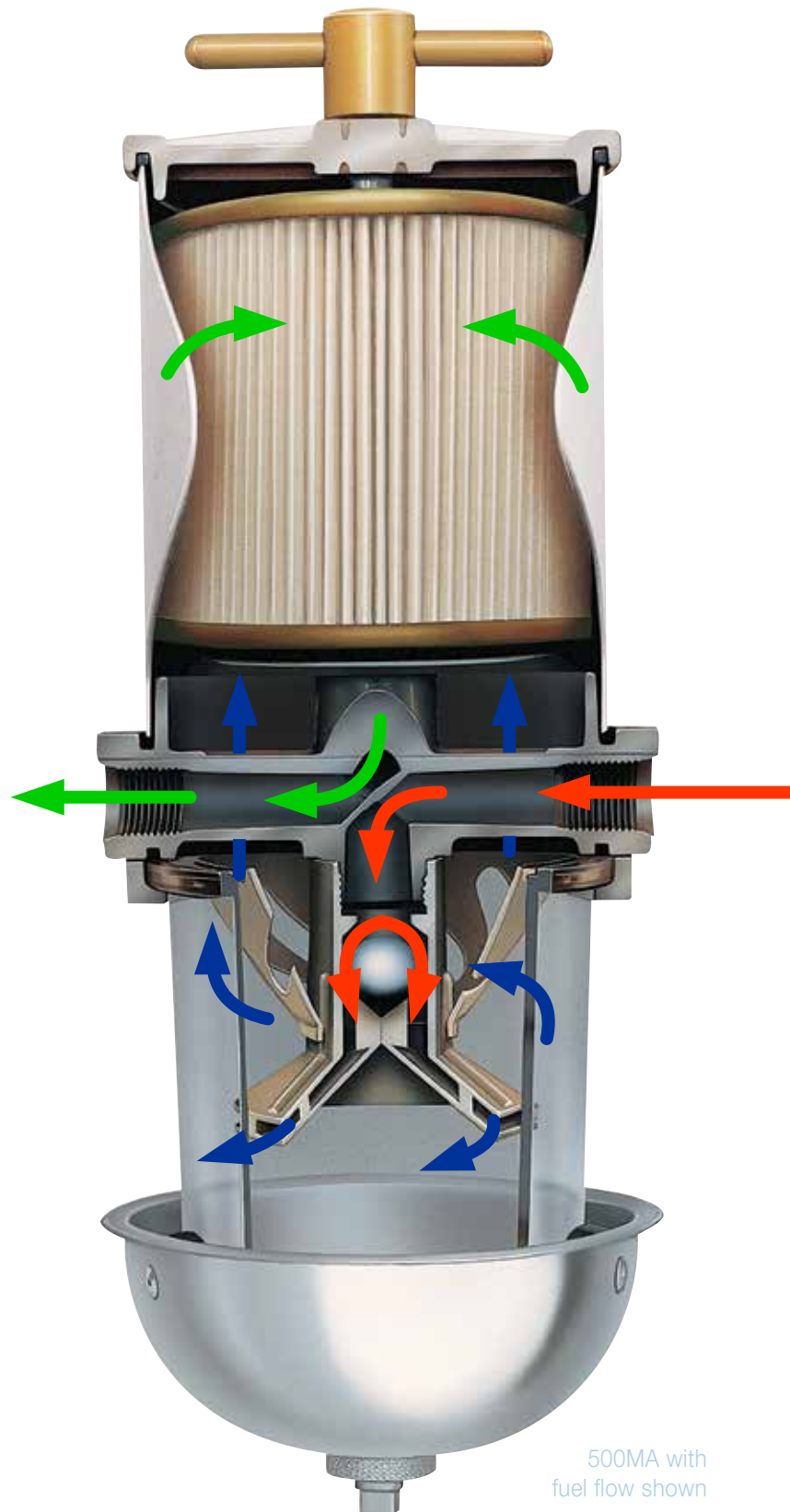

Mobile Diesel



Model	500FG2 /10 /30	900FH2 /10 /30	1000FH2 /10 /30	75500FGX2 /10 /30	75900FHX2 /10 /30
Max. Flow Rate (One filter on-line) (Two filters on-line)	60 GPH (227 LPH) N/A	90 GPH (341 LPH) N/A	180 GPH (681 LPH) N/A	60 GPH (227 LPH) 120 GPH (454 LPH)	90 GPH (341 LPH) 180 GPH (681 LPH)
Height	11.5 in. (29.2 cm)	17.0 in. (43.2 cm)	22.0 in. (55.9 cm)	11.5 in. (29.2 cm)	17.0 in. (43.2 cm)
Width	5.8 in. (14.7 cm)	6.0 in. (15.2 cm)	6.0 in. (15.2 cm)	14.5 in. (36.8 cm)	18.8 in. (47.8 cm)
Depth	4.8 in. (12.2 cm)	7.0 in. (17.8 cm)	7.0 in. (17.8 cm)	9.5 in. (24.1 cm)	11.0 in. (27.9 cm)
Weight (approx.)	4 lbs (1.8 kg)	6 lbs (2.7 kg)	17 lbs (7.7 kg)	17 lbs (7.7 kg)	23 lbs (10.4 kg)
Port Size (metric optional) ¹	3/4"-16 SAE 16 mm x 1.5	7/8"-14 SAE 22 mm x 1.5	7/8"-14 SAE 22 mm x 1.5	3/4"-16 SAE N/A	7/8"-14 SAE N/A
Clean Pres. Drop	0.3 PSI (0.02 bar)	0.34 PSI (0.02 bar)	0.49 PSI (0.03 bar)	0.70 PSI (0.05 bar)	1.7 PSI (0.12 bar)
Max. Operating Pressure ²	15 PSI (1.03 bar)	15 PSI (1.03 bar)	15 PSI (1.03 bar)	15 PSI (1.03 bar)	15 PSI (1.03 bar)
Replacement Filter	2010 Series	2040 Series	2020 Series	2010 Series	2040 Series
Overhead Clearance	4.0 in. (10.2 cm)	5.0 in. (12.7 cm)	10.0 in. (25.4 cm)	4.0 in. (10.2 cm)	5.0 in. (12.7 cm)
Ambient Temperature Range	-40° to +255°F (-40° to +124°C)				
Maximum Fuel Temperature	190°F (88°C)				

Notes: ¹ Use (*) for metric port threads, i.e. *500FG, *900FH, and *1000FH. ² Vacuum installations are recommended.



Model	731000FH2 /10 /30	751000FHX2 /10 /30	771000FH2 /10 /30	791000FHV2 /10 /30
Max. Flow Rate (One filter on-line) (Two filters on-line) (Three filters on-line)	N/A 360 GPH (1363 LPH) N/A	180 GPH (681 LPH) 360 GPH (1363 LPH) N/A	N/A N/A 540 GPH (2044 LPH)	180 GPH (681 LPH) 360 GPH (1363 LPH) 540 GPH (2044 LPH)
Height	22.0 in. (55.9 cm)	22.0 in. (55.9 cm)	22.0 in. (55.9 cm)	22.0 in. (55.9 cm)
Width	16.5 in. (41.9 cm)	18.0 in. (45.7 cm)	18.0 in. (45.7 cm)	21.5 in. (54.6 cm)
Depth	12.0 in. (30.5 cm)	11.0 in. (27.9 cm)	11.0 in. (27.9 cm)	11.8 in. (30.0 cm)
Weight (approx.)	26 lbs (11.8 kg)	30 lbs (13.6 kg)	39 lbs (17.7 kg)	52 lbs (23.6 kg)
Port Size	3/4"-14 NPT	7/8"-14 SAE	1"-11.5 NPT	3/4"-14 NPT
Clean Pres. Drop	1.7 PSI (0.12 bar)	3.7 PSI (0.26 bar)	1.7 PSI (0.12 bar)	2.5 PSI (0.17 bar)
Max. Operating Pressure ³	15 PSI (1.03 bar)	15 PSI (1.03 bar)	15 PSI (1.03 bar)	15 PSI (1.03 bar)
Replacement Filter	2020 Series	2020 Series	2020 Series	2020 Series
Overhead Clearance	10.0 in. (25.4 cm)	10.0 in. (25.4 cm)	10.0 in. (25.4 cm)	10.0 in. (25.4 cm)
Ambient Temperature Range	-40° to +255°F (-40° to +124°C)			
Maximum Fuel Temperature	190°F (88°C)			

Notes: ³ Vacuum installations are recommended.

Turbine Series Replacement Elements

The lower the micron rating the finer the filtration. Lower micron ratings should be considered when there is no additional downstream filtration.

Ultimately, the micron rating preferred will be a function of fuel quality, operating climates and maintenance schedules.

BUILD A PART NUMBER

ELEMENTS FOR 500 SERIES

2010SM-OR

2010 - 500 series | **SM** - 2 micron
TM - 10 micron | **-OR** - O-ring pack
PM - 30 micron



ELEMENTS FOR 900/1000 SERIES

2040N-02

2040N - 900 series | **-02** - 2 micron
2020N - 1000 series | **-10** - 10 micron
-30 - 30 micron



Specifications	2010SM-OR 2010TM-OR 2010PM-OR	2020N-02 2020N-10 2020N-30	2040N-02 2040N-10 2040N-30
Micron Rating & Filtration Level	2010SM-OR, 2 Micron, Final Filtration 2010TM-OR, 10 Micron, Secondary 2010PM-OR, 30 Micron, Primary ¹	2020N-02, 2 Micron, Final Filtration 2020N-10, 10 Micron, Secondary 2020N-30, 30 Micron, Primary ¹	2040N-02, 2 Micron, Final Filtration 2040N-10, 10 Micron, Secondary 2040N-30, 30 Micron, Primary ¹
Height	2.7 in. (6.9 cm)	9.6 in. (24.4 cm)	4.6 in. (11.7 cm)
Diameter	3.1 in. (7.9 cm)	4.7 in. (11.9 cm)	4.7 in. (11.9 cm)
Applications	500 Series	1000 Series	900 Series
Notes: ¹ A secondary or final filter is required downstream. Replacement seals included.			



GreenMAX™

Heavy-Duty, High-Capacity, Fuel Filter Water Separator With Options for All-Weather Operations



- Integrated Piston-Style Hand Priming Pump or Fill Port
- Hot Engine Return Fuel Recirculating Heater
- Dual Inlet / Outlet Ports
Low Restriction at High Flow Rates
- Patented Filter Valve Mechanism Holds Prime and Prevents Clean Side Contamination During Service
- Durable Multi-Port Cast Aluminum Mounting Head Assembly
- Easy to Mount with Through-Holes for a 3/8" Bolt and Tapped for a M8 Bolt
- Aquabloc® Synergy High-Capacity, High-Flow Filter Element
- Rated Diesel Flow Rate Change to 150 gph (568 lph)
- Optional 200W Electric In-Bowl Fuel Heater for Severe Cold Conditions (Not Shown)
- High-Capacity Removable, Reusable and Extremely Durable Bowl – A See-Thru Bowl That Stays See-Thru
- Water-In-Fuel (W/F) Water Sensor Alerts Operator for Service (1/2-20 SAE Port)

GreenMAX™ Fuel Filter Water Separator	
Rated Flow Rate	150 GPH (568 LPH)
No. of Ports	Inlet Ports: 2, Outlet Ports: 2
Port Size	-10 SAE (7/8-14 UNF)
Hand Primer Pump	Optional
Micron Rating Available	2, 10, 30, Depth Coalescer
Particulate Removal Efficiency (SAE J1839)	Min 98% (R61691T)
Water Removal Efficiency (SAE J1839)	Min 99% (R61691T)
Return Fuel Heat Valve (Thermostatically Controlled)	Optional: -8 SAE 45° Flare (3/4-16)
Electrical Heater 12 or 24 vdc	Optional (300W/200W)
Water Sensor	Optional (1/2-20 SAE port)
Vacuum (Maximum)	20" Hg
Ambient Temperature Range	-30° to +100° C
Maximum Fuel Temperature	
With Bowl Heater	71° C
WithouthBowl Heater	85° C
Fuel Compatibility	Diesel fuel per ASTM D975 and Biodiesel blends up to B20 per ASTM D7467
Optional Filter Change Indicator	Vacuum Indicator / Vacuum Switch

MODEL	DESCRIPTION
4400R02	GreenMAX FF/WS, W/Hand Primer Pump, 2 Micron
4400R10	GreenMAX FF/WS, W/Hand Primer Pump, 10 Micron
4400R30	GreenMAX FF/WS, W/Hand Primer Pump, 30 Micron
4400RDC	GreenMAX FF/WS, W/Hand Primer Pump, Depth Coalescer
4400R1202	GreenMAX FF/WS, 12v in bowl heater, W/Hand Primer Pump, 2 Micron
4400R1210	GreenMAX FF/WS, 12v in bowl heater, W/Hand Primer Pump, 10 Micron
4400R1230	GreenMAX FF/WS, 12v in bowl heater, W/Hand Primer Pump, 30 Micron
4400R12DC	GreenMAX FF/WS, 12v in bowl heater, W/Hand Primer Pump, Depth Coalescer
4400R2402	GreenMAX FF/WS, 24v in bowl heater, W/Hand Primer Pump, 2 Micron
4400R2410	GreenMAX FF/WS, 24v in bowl heater, W/Hand Primer Pump, 10 Micron
4400R2430	GreenMAX FF/WS, 24v in bowl heater, W/Hand Primer Pump, 30 Micron
4400R24DC	GreenMAX FF/WS, 24v in bowl heater, W/Hand Primer Pump, Depth Coalescer
4400R1210-01	GreenMAX FF/WS, W/Hand Primer Pump, 12 VDC Bowl Heater, 10 Micron, Return Fuel Heat
4400R2410-01	GreenMAX FF/WS, W/Hand Primer Pump, 24 VDC Bowl Heater, 10 Micron, Return Fuel Heat
6600R02	GreenMAX FF/WS, 2 Micron
6600R10	GreenMAX FF/WS, 10 Micron
6600R30	GreenMAX FF/WS, 30 Micron
6600RDC	GreenMAX FF/WS, Depth Coalescer
6600R1202	GreenMAX FF/WS, 12v in bowl heater, 2 Micron
6600R1210	GreenMAX FF/WS, 12v in bowl heater, 10 Micron
6600R1230	GreenMAX FF/WS, 12v in bowl heater, 30 Micron
6600R12DC	GreenMAX FF/WS, 12v in bowl heater, Depth Coalescer
6600R2402	GreenMAX FF/WS, 24v in bowl heater, 2 Micron
6600R2410	GreenMAX FF/WS, 24v in bowl heater, 10 Micron
6600R2430	GreenMAX FF/WS, 24v in bowl heater, 30 Micron
6600R24DC	GreenMAX FF/WS, 24v in bowl heater, Depth Coalescer
6600R1210-01	GreenMAX FF/WS, 12 VDC Bowl Heater, 10 Micron, Return Fuel Heat
6600R2410-01	GreenMAX FF/WS, 24 VDC Bowl Heater, 10 Micron, Return Fuel Heat
SERVICE	DESCRIPTION
R61691S	Replacement Element, GreenMAX 2 Micron
R61691T	Replacement Element, GreenMAX 10 Micron
R61691P	Replacement Element, GreenMAX 30 Micron
R61762	Replacement Element, GreenMAX Depth Coalescer

For a complete list of part numbers see cut sheet RSL0275.

Two heating options, including a patented engine return fuel recirculating technology, deliver free-flowing fuel even in the most severe weather conditions.

Cold Start In-Bowl Electric-Thermostatically Controlled Fuel Heating Options

To bring fuel quickly to operating temperatures in very cold conditions, optional 200W in-bowl heater is available. Thermostatically controlled and self-regulating, automatically shutting down once target fuel temperature is achieved.



To summarize GreenMax fuel heating options: Electric heaters help you get started; hot fuel recirculating keeps you running.

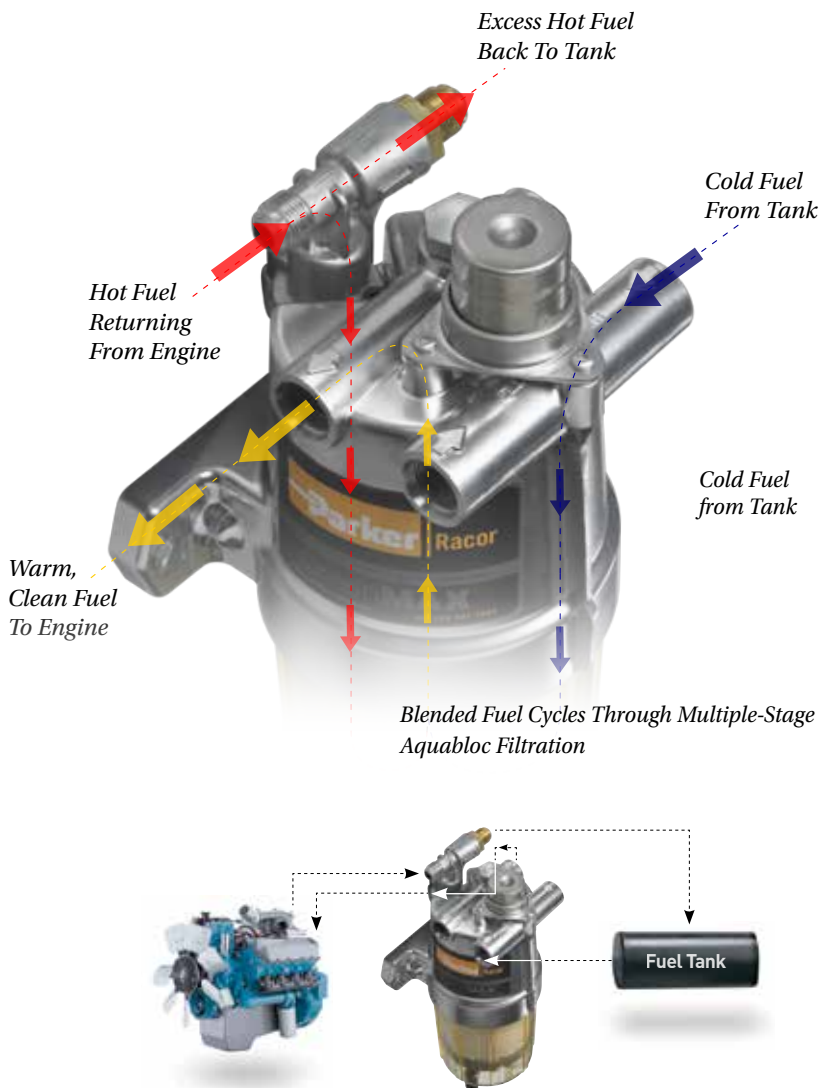

Engine Return Fuel Recirculation

The GreenMAX Fuel Filter Water Separator features an innovative patented technology that utilizes unused warm engine fuel returning to the tank to provide on-demand fuel heat transfer for cold weather operations. This cold weather feature directs engine return fuel into the GreenMAX prior to the filtration stage, melting the wax and paraffins that separate from diesel fuel at cold temperatures (cloud point) and restrict fuel flow.

When the fuel system temperature is stabilized for optimum fuel filtration and engine operation, the engine return fuel recirculation valve automatically redirects the hot engine return fuel to the fuel tank. The recirculating valve is self-regulating, sensing fuel temperature and automatically closing once the fuel is warm.

The engine return fuel is mixed with the GreenMAX incoming fuel flow from the fuel tank, providing optimum fuel temperature for efficient fuel filtration and engine performance.

SNAPP. The fuel filter change that changes everything.

SNAPP is big protection for small engines with fuel flows up to 40 gph and makes every filter change literally a snap. Fast, easy, clean. No tools are needed – when it’s time for service, simply snap in a new filter. Simple installation and a patented priming system mean that protecting your engine investment is now ... a SNAPP.

Fast, easy, clean, SNAPP is a fuel filter change for the better.

The world turns to Racor for filtration solutions that provide ultimate protection from water and solid contamination. This is filtration that includes two innovations often copied but never quite duplicated – the powerful protection of patented, world-class Aquabloc® Synergy filter media and, the Racor trademark, a clear bowl that allows for at-a-glance inspection of fuel system integrity.

Quick-release squeeze tabs make filter changes a snap.

Permanent mounting bracket is stainless steel or powder coated for withstanding corrosive environments.

SNAPP is a one-piece fuel filter water separator for 24/7 protection.

Heavy-duty high-impact nylon construction won't ever rust or corrode, even in humid conditions.

Clear bowl for at-a-glance inspection.

The rugged clear bowl allows on-the-spot inspection for water in fuel – a significant advantage when troubleshooting fuel quality.

The Racor self-venting drain means easy service with no mess – twist, drain, done.

Legendary Aquabloc® Synergy filter media in 2, 10 or 30 micron rating.

The Aquabloc® Synergy media is the world's definitive filtration protection – it's 99% effective in separating water and solid contamination from marine and diesel fuels.



Fuel Flow Specifications		
MICRON	GASOLINE	DIESEL
2	40 GPH	26 GPH
10	34 GPH	26 GPH
30	26 GPH	26 GPH

Part #	Description
Black Body	
23106-02	Fuel Filter Assy with Bracket – 02 Micron
23106-10	Fuel Filter Assy with Bracket – 10 Micron
23106-30	Fuel Filter Assy with Bracket – 30 Micron
R23107-02	Fuel Filter Replacement Element – 02 Micron
R23107-10	Fuel Filter Replacement Element – 10 Micron
R23107-30	Fuel Filter Replacement Element – 30 Micron
White Body	
23299-02	Fuel Filter Assy with Bracket – 02 Micron
23299-10	Fuel Filter Assy with Bracket – 10 Micron
23299-30	Fuel Filter Assy with Bracket – 30 Micron
R23298-02	Fuel Filter Replacement Element – 02 Micron
R23298-10	Fuel Filter Replacement Element – 10 Micron
R23298-30	Fuel Filter Replacement Element – 30 Micron

Specifications	
Maximum Flow Rate (Diesel)	26 gph (100 lph)
Aquabloc Micron Rating	2, 10, or 30 micron
Height	7.8" (198 mm)
Width	3.8" (97 mm) at bracket
Depth	4.1" (104 mm)
Water Sump Capacity	3.4 oz. (100 ml)
Body Material	Nylon 6 plastic
Bracket Material	Coated Steel / Stainless Steel
Port Size	3/8" (9.5 mm)
Quick-Connect Fittings	3/8" (9.5 mm) (per SAE J2044)
Rated Pressure	50 PSI (3.5 bar)
Water Removal Efficiency	99%
Rated Temperature Range	-20° to 150°F (-29° to 66°C)

In-Line Fuel Filtration

From personal watercraft to agricultural equipment, Racor in-line filters are designed to protect fuel pumps, carburetors, injectors and related fuel system components. We offer a complete range of disposable and cleanable in-line filters and prescreen products that work for diesel and gasoline applications.



MODEL NO.	025-RAC-01	025-RAC-02	025-RAC-10	025-RAC-11	025-RAC-12	PS120
Maximum Flow Rate	25 gph (95 lph)	25 gph (95 lph)	50 gph (189 lph)	15 gph (57 lph)	15 gph (57 lph)	120 gph (454 lph)
Maximum PSI/ kPa	5 psi (35 kPa)	5 psi (35 kPa)	5 psi (35 kPa)	5 psi (35 kPa)	5 psi (35 kPa)	5 psi (35 kPa)
Clean Pressure Drop	0.26 psi (1.8 kPa)	0.35 psi (2.4 kPa)	0.5 psi (3.5 kPa)	0.5 psi (3.5 kPa)	0.5 psi (3.5 kPa)	0.25 psi (1.7 kPa)
No. of Ports	2	2	2	2	2	2
Port Size	1/4" NPT	1/4" NPT	1/2" NPT	1/4" Barb	5/16" Barb	3/8"
Height	4.3 in. (109.2 mm)	4.3 in. (109.2 mm)	4.75 in. (120.7 mm)	3.45 in. (99.6 mm)	3.45 in. (99.6 mm)	7.25 in. (184.2 mm)
Width	2.25 in. (57.2 mm)	2.25 in. (57.2 mm)	4.19 in. (106.4 mm)	2.10 in. (53.3 mm)	2.25 in. (57.2 mm)	4.0 in. (101.6 mm)
Depth	2.10 in. (53.3 mm)	2.10 in. (53.3 mm)	1.88 in. (47.6 mm)	2.10 in. (53.3 mm)	2.10 in. (53.3 mm)	3.0 in. (76.2 mm)
Weight	0.3 lb (136 g)	0.3 lb (136 g)	0.3 lb (136 g)	0.3 lb (136 g)	0.3 lb (136 g)	0.75 lb (340 g)
Replacement Element	S2501	S2502	N/A	N/A	N/A	N/A

Fuel Filter Funnel



Racor Filter Funnel (RFF) is a heavy-duty, fast-flow, filter-in-a-funnel that separates damaging free water and contaminants from gasoline, diesel, heating oil, and kerosene.

The RFF family of products is capable of removing free water and solids down to 50 micron and allows you to visually inspect the integrity of your fuel supply as you refuel.

The RFF family is manufactured using industrial-grade black electro-conductive polypropylene. Carbon powder is injected into the plastic so that the RFF will conduct static electricity. The grounding capability of the RFF is an important safety feature. Always use proper fuel handling procedures and follow local, state, and federal regulations.

Caution for Users: Petroleum products flowing over a plastic surface generate static electricity. Caution should be taken to ensure that the RFF is grounded to reduce static electricity buildup and reduce the chance of explosions or fire. Electrically bond the funnel by using a wire with a metal clip on each end and clamp one to the upper rim of the funnel and the other to the fueling source. For example, the metal gas can or nozzle from the pump.



Specifications	FFC-110-06	FFC-110L-10	FFC-112	FFC-113	FFC-116N
Fuels Used	CNG	CNG	CNG	CNG	CNG
Filter Type	Coalescer	Coalescer	Coalescer	Coalescer	Coalescer
Maximum Pressure	800 PSI (5,500 kPa)	800 PSI (5,500 kPa)	3,600 PSI (24,800 kPa)	3,600 PSI (24,800 kPa)	5,000 PSI (34,400 kPa)
Max Flow Rate	25 SCFM (708 lpm)	50 SCFM (1,416 lpm)	15 SCFM (425 lpm)	50 SCFM (1,416 lpm)	8.4 SCFM (238 lpm)
Port Size	¼" NPT	½" NPT	¼" NPT	½" NPT	¼" NPT
Length	7.9 in. (18.3 cm)	10.4 in. (26.4 cm)	4.8 in. (12.2 cm)	8.0 in. (20.3 cm)	4.0 in. (10.1 cm)
Diameter	3.1 in. (7.9 cm)	3.1 in. (7.9 cm)	2.3 in. (5.8 cm)	3.0 in. (7.6 cm)	1.75 in. (4.4 cm)
Weight	1.5 lbs (0.7 kgs)	1.8 lbs (0.8 kgs)	1.5 lbs (0.7 kgs)	5.5 lbs (2.5 kgs)	1.75 lbs (0.8 kgs)
Clean Pressure Drop	1.0 PSI (6.9 kPa)	1.0 PSI (6.9 kPa)	3.0 PSI (20.7 kPa)	1.7 PSI (11.7 kPa)	1.25 PSI (8.6 kPa)
Sump Capacity	5.0 oz. (148 cc's)	7.0 oz. (207 cc's)	0.5 oz. (15 cc's)	5.0 oz. (148 cc's)	0.25 oz. (7.4 cc's)
Temperature	-40°/+221° F (-40°/+105° C)				

- Notes:**
1. For accurate flow rates and pressures, consult your engine manual, engine manufactures agent, or the vehicle manufacturer.
 2. Some specifications are the result of tests conducted at the optimum flow rate.
 3. Allow 3.0 in. (7.6 cm) of clearance below assembly for draining and maintenance of element.
 4. Filter element kit, includes element and replacement seals.

For complete product information, see brochure RSL0075.

Typical Application

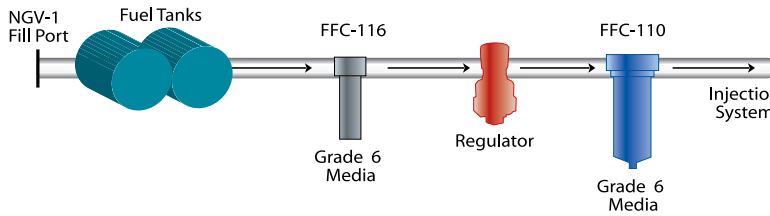

Media types, grades & efficiencies

Coalescing:

Coalescing elements are specially designed for the removal of liquid contaminants from gaseous flows. These media types flow from the inside of the element to the outside. Coalesced liquid (water and oil) collects in the bowl where it is drained, while clean air or gas exits the housing through the outlet port. Particulate contaminants are captured and held in the media.



Grade 6

Grade 10

Media Grades:

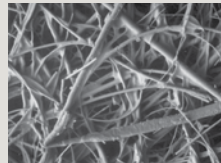
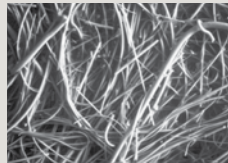

Grade 6 filter elements are used when “total removal of liquid aerosols and suspended fines” is required. Because of its overall performance characteristics, this grade is most often recommended below 500 PSIG.

Grade 10 filters are used as prefilters for grade 6 to remove gross amounts of aerosols or tenacious aerosols which are difficult to drain. This grade is often used as a ‘coarse’ coalescer.

FFC series filters are designed to protect critical engine components in CNG powered vehicles. Contaminants can be introduced into a vehicle’s fuel tank when being fueled or may come from compressors and/or storage facilities. A grade 6 coalescing filter is specifically designed to remove oil, water, and solid contamination from compressed natural gas.

The patented coalescing filter removes 99.97% of all aerosols in the 0.3 to 0.6 micron range.

These fuel filter/coalescer elements are produced by a patented process of arranging micro-glass fibers into a tubular form. During operation, fuel is forced through the coalescing media from the inside of a cartridge through a tubular wall to the outside, where large droplets fall to the bottom of the housing. Oily water emulsion accumulates until drained while dirt particles remain trapped and collect on surfaces of fibers.



Type C, For use with:

- FFC-110 (800 PSIG)
- FFC-110L (800 PSIG)
- FFC-112 (3600 PSIG)
- FFC-112 SAE (3600 PSIG)
- FFC-113 (3600 PSIG)

Composed of an epoxy saturated, borosilicate glass microfiber tube in intimate interlocking contact with a rigid retainer. Surrounded by a coarse fiber drain layer, retained by a synthetic fabric safety layer. Some models are available with molded elastomeric end seals (CU), or with metal end caps and fluorocarbon gaskets.



Element change-out indicator is optional.

The slotted locking ring collar attaches the filter housing to the aluminum die cast filter head with four bolts. Metal hand knobs are provided for ease of maintenance.

Powdercoated components capable of 150 psi @ 240° F max design pressure.

Steel filter bowl assembly, a manual vent valve and a manual drain valve help provide ease of service – especially significant given the FBO assembly’s wide range of installations, including fuel trucks, fueling cabinets, diesel fuel dispensing systems, fuel docks and fuel systems on large diesel engines. 1 1/2" NPT inlet and outlet.

Water level sight plug is optional.



FBO Filter Assembly

Racor’s FBO-10 and FBO-14 filter assemblies are designed to meet the toughest hydrocarbon refueling conditions and provide for ease of filter change-outs.

The assembly features a locking ringcollar, which attaches the filter housing to the aluminum die cast filter head with four bolts. The slotted locking ring collar allows maintenance personnel to hand-loosen the four collar bolts, rotate and lower the bowl assembly for element change-outs. With new element installed, simply raise the bowl and rotate into position on the locking ring and hand tighten evenly.

The closure hardware consists of stainless steel nuts, bolts and washers with metal hand knobs for ease of maintenance – one person can easily change the filter element. No wrenches or other special tools are required.

Performance Specifications

FBO-10	Maximum Flow Rates			Clean Dry	Change
	Flow Range	Diesel	Gasoline	Delta P	Delta P
Prefilter	5-40 gpm	20	50	**	20 PSID
Filter Sep	5-35 gpm	18	45	**	15 PSID
Absorber	5-25 gpm	18	45	**	30 PSID
FBO-14	Flow Range	Diesel	Gasoline	Delta P	Delta P
Prefilter	10-60 gpm	30	75	**	20 PSID
Filter Sep	10-50gpm	25	65	**	15 PSID

**Varies with fluid and flow rate.

For complete product information, see brochure RSL0020.

How to Order

Guide to help you specify the right FBO system with the accessories you need.

F B O - 1 0 - D P

Flow Rates

10 = 5-25 GPM (19-95 LPM)

14 = 10-30 GPM (38-114 LPM)

DP = Differential Gauge

DPL = Delta-P Gauge with
Liquid Sight Glass

MA = Marine Assembly

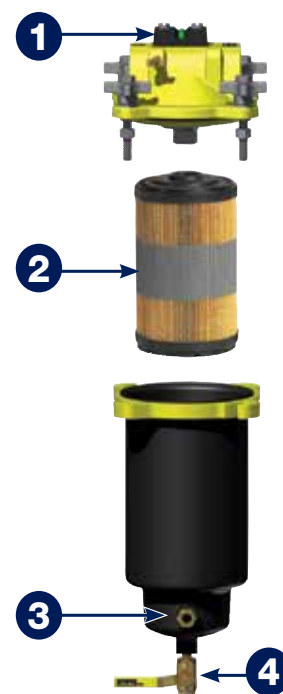

****Popular Option**

	1	2	3	4
	Delta-P Gauge	Filter	Sight Glass	Drain Valve
FBO-10		Order Separately (see below)		•
FBO-10-DP	•	Order Separately (see below)		•
FBO-10-DPL**	•	Order Separately (see below)	•	•
FBO-14		Order Separately (see below)		•
FBO-14-DP	•	Order Separately (see below)		•
FBO-14-DPL**	•	Order Separately (see below)	•	•
FBO-10-25M	•	FBO 60332	•	•
FBO-14-25M	•	FBO 60341	•	•

Replacement Filters

FBO	Micron Rating	Coalescer/ Separator	Particulate	Water Absorber
FBO-10 (6 X 10 Filter)	1	FBO 60327	FBO 60330	FBO 60333
	5	FBO 60328	FBO 60331	FBO 60334
	10	FBO 60353	FBO 60354	FBO 60355
	25	FBO 60329	FBO 60332	FBO 60335
FBO-14 (6 X 14 Filter)	1	FBO 60336	FBO 60339	FBO 60342
	5	FBO 60337	FBO 60340	FBO 60343
	10	FBO 60356	FBO 60357	FBO 60358
	25	FBO 60338	FBO 60341	FBO 60344

Coalescer/Separator

Coalescer/separator filters are a two stage element that removes water and contaminants from diesel fuel streams and are the most popular filters.

Particulate Filter

Particulate filters remove contaminants down to one micron. Particulate filters can also be used upstream, before a water separator filter, to extend filter life.

Water Absorber

Water absorber filters absorb water and filter out contaminants from diesel fuel.

Portable Diesel Filtration

These portable units are a cost effective way to filter diesel and biodiesel, in storage or transport. Filter Carts are fully portable and self-contained. They are easily moved at the job-site by one person using the built-in wheels and handle. Filter carts can polish, clean up, and recycle old or contaminated fuel. They can also be used in preventative maintenance practices to keep fuel tanks clean.

Features and Benefits

- Versatile and portable
- Viton® seals and gaskets
- Sight glass and drain valve to detect and remove water
- Particulate removal, coalescer/separation, and water absorption filtration
- Drip pans to capture dripping fluids and prevent environmental issues
- Filter shows differential pressure for filter element changeout

Viton® is a registered trademark of DuPont™



Part# shown:
FC-16-25



Part# shown:
FC-10-1

	FC-16-25	FC-10-1
Enclosed Cart		•
2 Wheel Cart	•	•
Holding Tank		•
Additional Mesh Strainer		•
FBO-10		•
FBO-14	•	
5 micron element		•
25 micron element	•	
120V Power Requirement		•
110V Power Requirement	•	
Hose Kit/Wands	•	•
Flow Rate (GPM)	16	10

300RC Series

The 300RC Series Diesel Fuel Filter/Heater/Water Separators are specifically designed to handle today's tough cold weather and Biodiesel fuel system problems. These units feature a standard high-efficiency coolant heat exchanger to heat incoming fuel.

- High-capacity media – the Racor Aquabloc® Synergy media allows for excellent contaminant removal and water separation. Available in 2,10, and 30 micron ratings.
- Highly efficient heaters – utilizing heat from the engine's coolant, the heat exchanger transfers heat to the fuel quickly and efficiently.
- Highly efficient water coalescing.
- Biodiesel tested rubber seals and gaskets to prevent swelling.



MODEL	345RC2 /10 /30	360RC2 /10 /30	390RC2 /10 /30
Fuel Ports	3/8 NPTF	3/8 NPTF	3/8 NPTF
Replacement Element	R45	R60	R90
Flow Rate	45 gph / 170 lph	60 gph / 227 lph	90 gph / 341 lph
Height	8.7" / 221 mm	10.4 / 264 mm	11.25 / 286 mm
Width	4" / 102 mm	4" / 102 mm	4" / 102 mm
Depth	4.8" / 122 mm	4.8" / 122 mm	4.8" / 122 mm
Temperature	-40°F / +255°F -40°C / +121°C	-40°F / +255°F -40°C / +121°C	-40°F / +255°F -40°C / +121°C



Compact Fuel Heater

Plumbed into the fuel upstream from filters, the coolant heater is another compact way to run through the cold. An optional internal thermostatically-controlled valve allows fuel to bypass the heater once it has reached operating temperature. Depending on fuel flow rate, you can get as much as 89°F heat rise. Like its electric partner, there are no moving parts, nothing to rust or corrode.



Why you need a Racor fuel heater.

All diesel fuels (other than #1) contain dissolved waxes. At cold temperatures the wax crystallizes, leading to filter plugging and fuel gelling. These changes greatly reduce fuel flow, adversely affecting the operability of vehicles.

With the increased popularity of biodiesel, and the use of ultra low sulfur diesel (ULSD), there are new cold weather challenges. While proper fuel winterization normally avoids trouble, both biodiesels and ULSD may experience wax crystallization and gelling at higher than expected temperatures and contribute to cold fuel flow problems anyway.

Keeping this in mind, it is more necessary now than ever to design an efficient fuel heating system for all cold weather applications.

Racor offers a number of efficient heaters. Compact coolant and electric heaters install in minutes, yet deliver years of trouble-free service. There is even an in-line heater which actually turns a fuel line into a heated path from tank to filter.

Spin-On Series In-Bowl Heaters

Racor equips the Spin-On Series fuel filter/water separators with the option of a 200W resistance heater integrated into the bowl. Placing the heat source just below the element allows for maximum transfer. Racor Spin-On Series In-Bowl heaters are available installed in assembly upon order (consult catalog for part numbers) or as a retrofit kits.



Spin-On Series In-Bowl Heaters

Part No.	RK 22354-01	RK 22354-02	RK 30900	RK 30925
Heater Retrofit Kit For	200 Series	200 Series	3150, 3250, 4120, 6120	3150, 3250, 4120, 6120
Wattage	200W	200W	200 W	200W
Voltage	12V	24V	12V	24V
Bowl Type	Clear	Clear	Clear	Clear

Part No.	RK 22616-01	RK 22616-02	RK 30895	RK 30924
Heater Retrofit Kit For	300RC, 400, 600 Series	300RC, 400, 600 Series	320 Series	320 Series
Wattage	200W	200W	200 W	200W
Voltage	12V	24V	12V	24V
Bowl Type	Clear	Clear	Clear	Clear

Turbine Series Heater

The Racor Turbine Series comes available with a powerful heater situated directly below the filter element to assist with cold starting. Thermostats are standard to meet the requirements of today's advanced electronic engines. These heaters begin to work in just a few moments and place minimal demand on the battery. Racor Turbine Series heaters are available installed in assembly upon order (consult catalog for part numbers) or as a retrofit kits.



300 Series In-Head Heater

The in-head 150W heater is a cold weather aid and is thermostatically controlled when power is provided. The heater will automatically turn on if the fuel temperature drops below 45°F (7°C) and will automatically turn off at 75°F (24°C). Heat is supplied directly below the inlet port to melt the wax crystals and allow fuel to efficiently pass through the element. The heater is operated by turning the ignition switch on for a minimum of five minutes prior to starting the engine.



Thermoline™ In-Fuel-Line Heater

The heavy-duty Thermoline™ Diesel Fuel Heater comes installed inside a new fuel line and literally replaces the fuel line between the tank and the primary filter. It prevents power loss and stall, and assists starting down to -40°F. This heated path is recommended for extended use in cold weather environments and severe conditions.

Thermoline In-Fuel-Line Heater comes factory pre-wired with all hardware, ready for quick installation.



Nomad Electric Heaters



The Racor Nomad Diesel Fuel Heater is available in 300 and 500 watts and is one of the most compact, most efficient ways to heat fuel on the road today.

Installation usually takes about an hour. An optional frame rail mounting bracket eliminates drilling and welding.

For complete product information, see brochure 7749.

Features and Benefits

- Durable and compact WIF housing
- 1/2"-20 UNF threads with SAEJ1926 o-ring seal design
- Hermetically sealed against water and fuel
- Use with 12 or 24 vdc
- Gold plated brass probe tips
- Corrosion proof materials
- Color-coded for easy visual identification
- WIFs include mating, detachable and locking wire harness connectors

Water Detection Probes

Racor's Water-In-Fuel (WIF) Probes are designed to be robust and feature gold plated metallic probe tips and water tight, detachable and locking wiring harness connectors.

Water probes are passive sensors that work in conjunction with active electronic detection amplifiers. The probes are installed in the bottom of Racor fuel filter/water separator contaminant collection bowls. When accumulated water levels rise to the level of the metallic probe tips, the detection amplifier analyzes the change in electrical resistance (in ohms) and activates an alarm or lamp (depending on the detection amplifier used).

The WIF probes are available in three versions and colors. The version chosen depends on the equipment's Electronic Control Module (ECM) requirements; 83K ohms (blue body) or 220K ohms (black body). For applications not requiring this match, the non-resistor version (green body) should be used.

Detachable Locking Wire Harness

The detachable wire harness adds a convenience to remove the connection when servicing the spin-on filter or contaminant collection bowl. To remove, slide the red "safety-lock" away from the WIF probe. Next, press down on the black tab lever and pull the connector away from the WIF. To reconnect, just push the harness connector onto the WIF. It is specially "keyed" and will fit only one way.

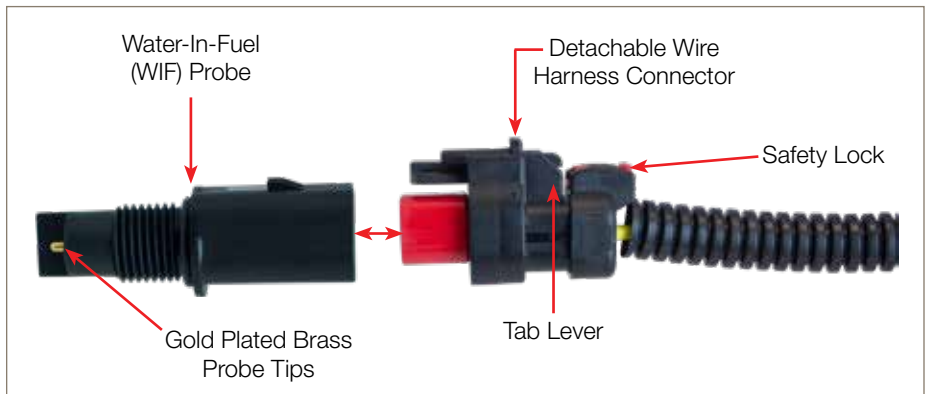

Specifications	RK 55484	RK56235	RK33801	RK33802	RK33803	RK55725	RK55726	RK56236	RK56237
Mating Connector	Delphi Packard 12162000	Delphi Packard 12162000	None	None	None	Deutsch DT042P-E003	Deutsch DT042P-E003	Delphi Packard 12052641	Delphi Packard 12052641
Thread Size	1/2"-20 UNF								
Volts	12 or 24	12 or 24	12 or 24	12 or 24	12 or 24	12 or 24	12 or 24	12 or 24	12 or 24
Probe Tips	Gold Plated Brass	Gold Plated Brass	Gold Plated Brass	Gold Plated Brass	Gold Plated Brass	Gold Plated Brass	Gold Plated Brass	Gold Plated Brass	Gold Plated Brass
Wire Length (L)	8.0 in. (20.3 cm)	4.0 in. (10.2 cm)	6.0 in. (15.2 cm)	8.0 in (20.3 cm)	8.7 in (22.1 cm)	6.0 in (15.2 cm)	12.0 in (30.5 cm)	14.0 in (35.6 cm)	5.0 in (12.7 cm)
Internal Resistor	220K ohm	220K ohm	82.5K ohm	None	None	82.5K ohm	82.5K ohm	220K ohm	220K ohm
Application	Cummins	-	Cummins	All	All	Cummins	Onan	Bluebird	Daimler

All Racor 2-wire WIFs must be connected to an additional component called a water detection amplifier.

Water Detection Modules & Kits

Racor Water Detection Kits are available in a wide selection for various installation requirements. Under-dash, in-dash, and remote mount, these solid-state units may be used with any Racor fuel filter/water separator and water probe. They are manufactured using the highest quality materials and

are all 100% electrically tested. An electronic detection module analyzes electrical resistance at the water probe and determines if water is present. If so, the detection module operates to indicate water, based on its features listed below. All units reset automatically after water is removed (unless specified).

Caution: The water probe and detection modules work with 12 or 24 volts, direct current only and should never be wired to other brand modules or household 110 or 220 volts, alternating current. Use the guide below to find the correct detection module for your application.

Part Number	Description	Voltage	Image
RK 12870	Under-dash water detection module. Light illuminates and alarm sounds when water is detected. Water must be drained to reset light and stop alarm. Plastic enclosure measures: 1.38" square x 1.25" deep. Water probe included.	12 vdc	
RK 12871	Same as above	24 vdc	
RK 20725	Under-dash mount water detection module. Light only. Green 'ON' lamp illuminates with power on. Red 'DRAIN' lamp illuminates when water is detected. Initial power-up self diagnosis feature and circuit protection included. Plastic enclosure measures: 2.75" x 1" x 1.5". Water probe included.	12 vdc	
RK 20725-24	Same as above	24 vdc	
RK 20726	2" gauge-type water detection module. Light and audio. Red 'DRAIN' lamp illuminates and horn sounds when water is detected. Initial power-up self diagnosis feature and circuit protection included. Plastic case, satin black dial with white lettering. Water probe included.	12 or 24 vdc	
RK 11-1570 ¹	2" gauge-type water detector and filter restriction module. Includes pre-set vacuum switch (7 inHg), connector, and outlet adapter fitting. Red 'DRAIN' or 'CHANGE FILTER' lamp illuminate and horn sounds when water is detected. Water probe included.	12 or 24 vdc	
RK 14329	Remote detection unit sends 12 VDC hot (+) signal when an input ground signal (from a water probe or a vacuum switch—not included) is received. Must be used with a relay to power a horn or indicator lamp (if draw is over 1 amp). Plastic enclosure measures: 3" x 2.5" x .75"	12 vdc	
RK 14321	Same as above	24 vdc	
14332	Under-dash mounts same as RK 14329 but sends a ground (-) signal. Enclosure size is same as RK 20725 above.	12 vdc	
RK 20163	Vacuum Switch Kit Non-adjustable, 'Normally Open' contacts close at 7 inHg (3.4 PSI) 1/8"-27 NPT threads. For use with all models.	N/A	
RK 21030	Vacuum Switch Connector Kit Molded connector with single 18 AWG., 18" blue wire lead.	N/A	
RK30880E	This kit includes new and enhanced detection electronics built into the probe body and works with 12 or 24 volt DC systems. Water probe and detection module all in one.	12 or 24 vdc	

¹ Clear collection bowl must have a 7/8" SAE port.

Accessories

Enhance Your Fuel Systems Performance and Ease of Service

When is My Engine Fuel Filter “Used Up?”







To ensure optimum filter efficiency and avoid sudden down time, filters should be changed before they clog completely. One way to know when the engine fuel filter has reached it's capacity is to measure the restriction at service.

An effective way to verify restriction is with a fuel filter restriction indicator. A restriction indicator will provide a quick assessment of the fuel filter's condition and remaining service life.



Vacuum restriction indicators monitor element condition as the filter slowly becomes clogged with contaminants. As the element gets dirty, restriction increases and less fuel is delivered to your engine causing the engine to lose power and eventually stall. By installing a vacuum indicator in your fuel system, visual monitoring of element condition is possible at a glance, increasing fuel system troubleshooting efficiency, eliminating guess work, and lengthening element change intervals.

Part Number	Thread Size
RK 32036	3/8" SAE Threads
RK32037	1/8" NPT Threads

Part No.	Description	Thread Size	
RK19668	Vacuum Gauge	1/4" NPT Back Mount With Bracket	
7232-4	Adapter Fitting	1/8" MNPT x #4 (1/4") Hose	
0102-4-2	Adapter Fitting	1/4" NPTM x 1/8" NPTF	
RK19669	Vacuum Gauge for Turbine Series fuel filter / water separators	1/4" NPT Bottom Mount	
RK19671	Vacuum Gauge for Turbine Series fuel filter / water separators, Stainless Steel T-handle	1/4" NPT Bottom Mount	
RK 19492	UL-Listed Brass Drain Valve	1/4" NPTF	

Vacuum/Compound Gauge Kits

Vacuum and Compound (vacuum/pressure) gauges and related hardware are available to monitor filter condition. As the filter slowly becomes clogged with contaminants the restriction (resistance to flow) increases. The fuel pump still tries to draw fuel (suction) but because of this restriction less fuel is delivered to the engine and instead more air is pulled from it (fuel de-gassing). These results can cause the engine to lose power and eventually stall. By installing a vacuum gauge in your fuel system (on the outlet side of the Racor filter) visual monitoring of filter condition is possible at a glance. Note the position of the dial, or apply the 'red line' decal provided with most kits. This will assist in easy monitoring as filter efficiency begins to decrease when a filter change is necessary.

Note: Intervals of filter changeout may vary depending on fuel cleanliness. Always keep a spare Racor filter on hand.



PFHG15LF
30/60 PSI Gauge

Worldwide Filtration Manufacturing Locations

North America

Compressed Air Treatment

Gas Separation & Filtration Division

Airtek/Finite/domnick hunter/Zander
Lancaster, NY
716 686 6400
www.parker.com/faf

Balston
Haverhill, MA
978 858 0505
www.parker.com/balston

Engine Filtration

Racor

Modesto, CA
209 521 7860
www.parker.com/racor

Holly Springs, MS
662 252 2656
www.parker.com/racor

Hydraulic Filtration

Hydraulic & Fuel Filtration

Metamora, OH
419 644 4311
www.parker.com/hydraulicfilter

Laval, QC Canada
450 629 9594
www.parkerfarr.com

Velcon
Colorado Springs, CO
719 531 5855
www.velcon.com

Process Filtration

domnick hunter Process Filtration SciLog

Oxnard, CA
805 604 3400
www.parker.com/processfiltration

Water Purification

Village Marine, Sea Recovery, Horizon Reverse Osmosis

Carson, CA
310 637 3400
www.parker.com/watermakers

Europe

Compressed Air Treatment

domnick hunter Filtration & Separation

Gateshead, England
+44 (0) 191 402 9000
www.parker.com/dhfn

Parker Gas Separations

Etten-Leur, Netherlands
+31 76 508 5300
www.parker.com/dhfn

Hiross Zander

Essen, Germany
+49 2054 9340
www.parker.com/hzfd

Padova, Italy
+39 049 9712 111
www.parker.com/hzfd

Engine Filtration & Water Purification

Racor

Dewsbury, England
+44 (0) 1924 487 000
www.parker.com/rfde

Racor Research & Development

Stuttgart, Germany
+49 (0)711 7071 290-10

Hydraulic Filtration

Hydraulic Filter

Arnhem, Holland
+31 26 3760376
www.parker.com/hfde

Urjala, Finland
+358 20 753 2500

Condition Monitoring Parker Kittiwake

West Sussex, England
+44 (0) 1903 731 470
www.kittiwake.com

Process Filtration

domnick hunter Process Filtration Parker Twin Filter BV

Birtley, England
+44 (0) 191 410 5121
www.parker.com/processfiltration

Asia Pacific

Australia

Castle Hill, Australia
+61 2 9634 7777
www.parker.com/australia

China

Shanghai, China
+86 21 5031 2525
www.parker.com/china

India

Chennai, India
+91 22 4391 0700
www.parker.com/india

Parker Fowler

Bangalore, India
+91 80 2783 6794
www.johnfowlerindia.com

Japan

Tokyo, Japan
+81 45 870 1522
www.parker.com/japan

Korea

Hwaseon-City
+82 31 359 0782
www.parker.com/korea

Singapore

Jurong Town, Singapore
+65 6887 6300
www.parker.com/singapore

Thailand

Bangkok, Thailand
+66 2186 7000
www.parker.com/thailand

Latin America

Parker Comercio Ltda. Filtration Division

Sao Paulo, Brazil
+55 12 4009 3500
www.parker.com/br

Pan American Division

Miami, FL
305 470 8800
www.parker.com/panam

Africa

Aeroport Kempton Park, South Africa
+27 11 9610700
www.parker.com/africa



WARNING: The products described in this catalog can expose you to chemicals including Diisononyl phthalate, Carbon black, which are known to the State of California to cause cancer. For more information go to www.P65Warnings.ca.gov.

Parker Hannifin Corporation
Filtration Group Global Headquarters
6035 Parkland Boulevard
Cleveland, OH 44124-4141
phone 216 896 3000
www.parker.com