



Technical Datasheet

LKF Coalescence Filter

We reserve the right to make technical changes without prior notice.

1 Filter functions

All filters of the LKF Series indicate the same function scope.

1.1 System connections

The filter has three connections to the left and right in each case. The function of these connections can be seen in the following sketch. The draining off of the separated water is implemented through a special drain plug below on the filter.

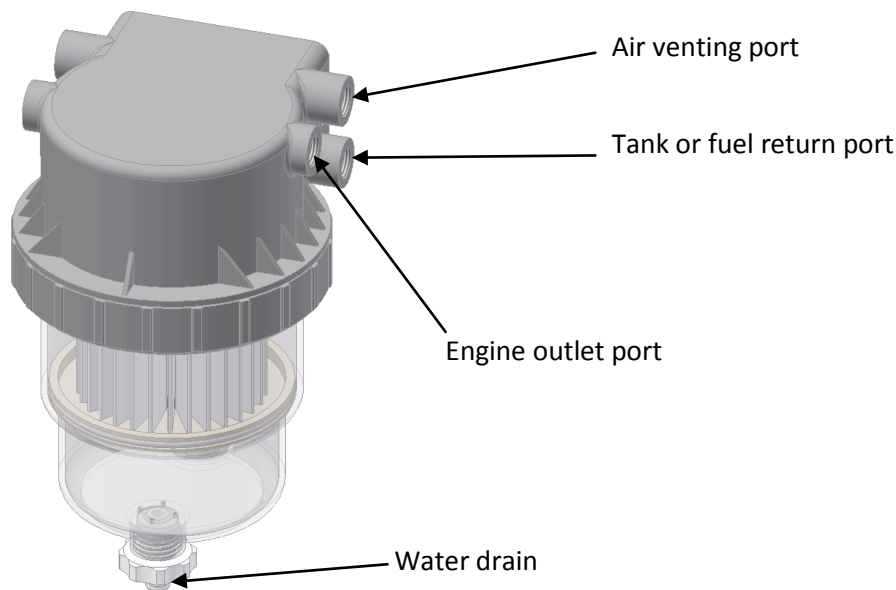

1.2 Filtering

The standard filter elements are equipped with two different filter media. With the external filter medium, it involves a special coalescence medium through which the water droplets are enlarged with transition to such an extent that they can be securely separated on the inner, hydrophobic filter medium. The separated water collects in the lower part of the filter bowl (see sketch below).

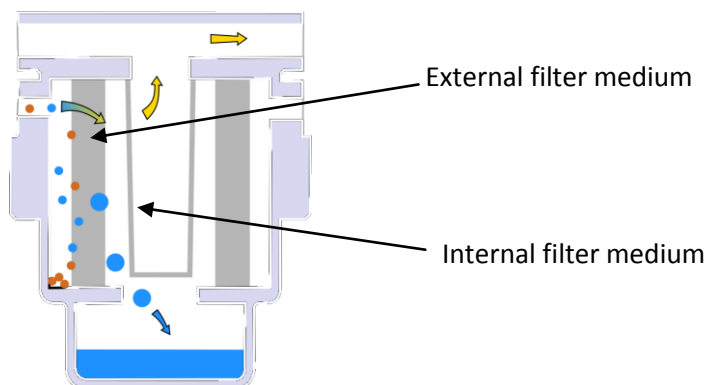

The fuel circulation quantity in case of modern engines is far higher than the actual fuel consumption of the engine itself. The service life of the filter element can be significantly increased with the

connection of the fuel return-routing to the filter, since the already cleaned fuel is injected again into the circuit and only small quantities of fresh fuel are required from the tank.

1.3 Heating

All filters can be equipped with an external, electrical filter heating. This heating is employed upstream of the filter in the direction of flow. The heating capacity can be up to 600 W.

The fuel conveyed back from the engine is usually far warmer than the fuel from the tank. The available heat here, which is significantly above the heat quantity of an external heating, can be used for the heating of the filter. For this purpose, the fuel return flow line is connected to the filter, exactly as described under the point Filtering.

1.4 Air venting

The air dissolved in the fuel can escape at sharp edges and pressure variations result from this. If these air bubbles occur in the filter, they collect at the highest point in the filter. From here, the air can be pumped out during operation through one of the air venting connections. For this, a corresponding pump-off device is necessary.

1.5 Water drainage

The separated water is easily identifiable through the transparent bowl of the filter. Optionally, a water sensor can also be employed for signalling to the vehicle.

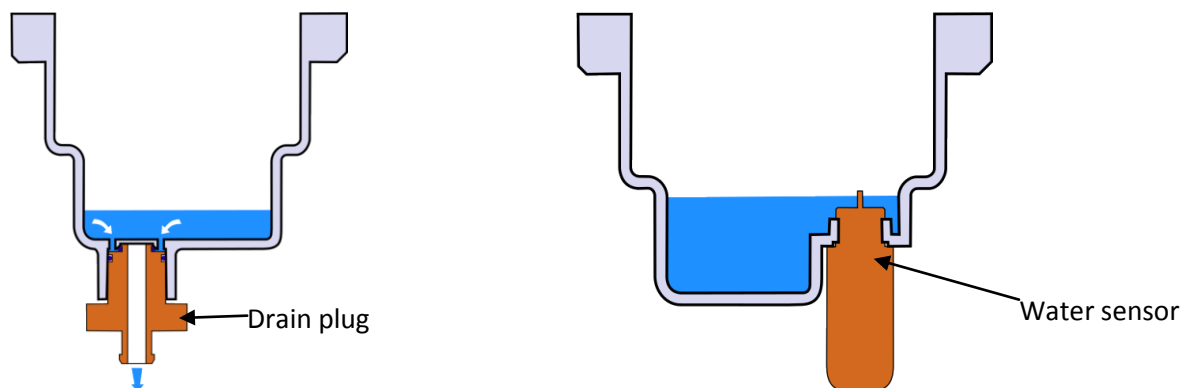

The routing away of the separated water can be implemented simply and cleanly through the special drain plug.

1.6 Identification

Every filter is identified unambiguously and thus secure against forgery. The identification is implemented by means of a transponder in the filter top, which can also be read out with soiled or painted-over filter.

2 Technical data LKF-Industrial

Areas of application	Diesel fuels, separation of water and fuel		
Flowrate		approx. 8 l/min	
Separation process	Water		Coalescence medium + hydrophobic water blocking
	Solid matter		Mechanical over filter medium and sedimentation upstream of the filter element
Filter surface area		approx. 17 dm ²	
Filter pore size		10 µm	Insert separately changeable
		6 µm	Insert separately changeable
Degree of water separation		> 95%	ISO/TS 16332
Differential pressure on the filter		< 50 mbar	At 8 l/min and 20°C fuel temperature Fuel according to EN 590
Dimensions	Width	approx. 150 mm	
	Depth	approx. 150 mm	
	Height	approx. 250 mm	
Necessary installation height	Height	approx. 330 mm	Including space for water drain and filter withdrawal
Weight	Metal design	< 1.3 kg	Aluminium
	Plastic design	< 0.8 kg	Glass-fibre-reinforced PA
Temperature ranges	Operation	-25 °C ... +70 °C	
	Storage	-25 °C ... +70 °C	
Fixing		2 x M8	Optional M8 bolts, internal screw-threads or link plates with 8.5 mm bore.
Pipe connections	Standard thread	6 x M16 x 1.5	
Fuel heating	Internal		Use of the waste heat from fuel return flow
	External (optional)		Separate, controlled fuel heater to 600 W
Water separation capacity		ca. 200 ml	
Water alarm at		ca. 160 ml	
Sensor technology (optional)	Water detection		Separate sensor
	Filter wear		Separate sensor
	Temperature monitor		Separate sensor

Willibrord Lösing Filterproduktion GmbH

W. Lösing Filterproduktion GmbH • Am Walzwerk 2 • 45527 Hattingen



Sketch: LKF-Industrial

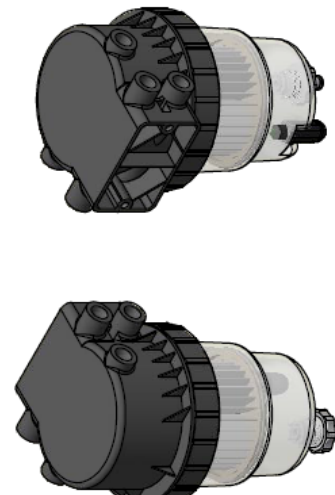
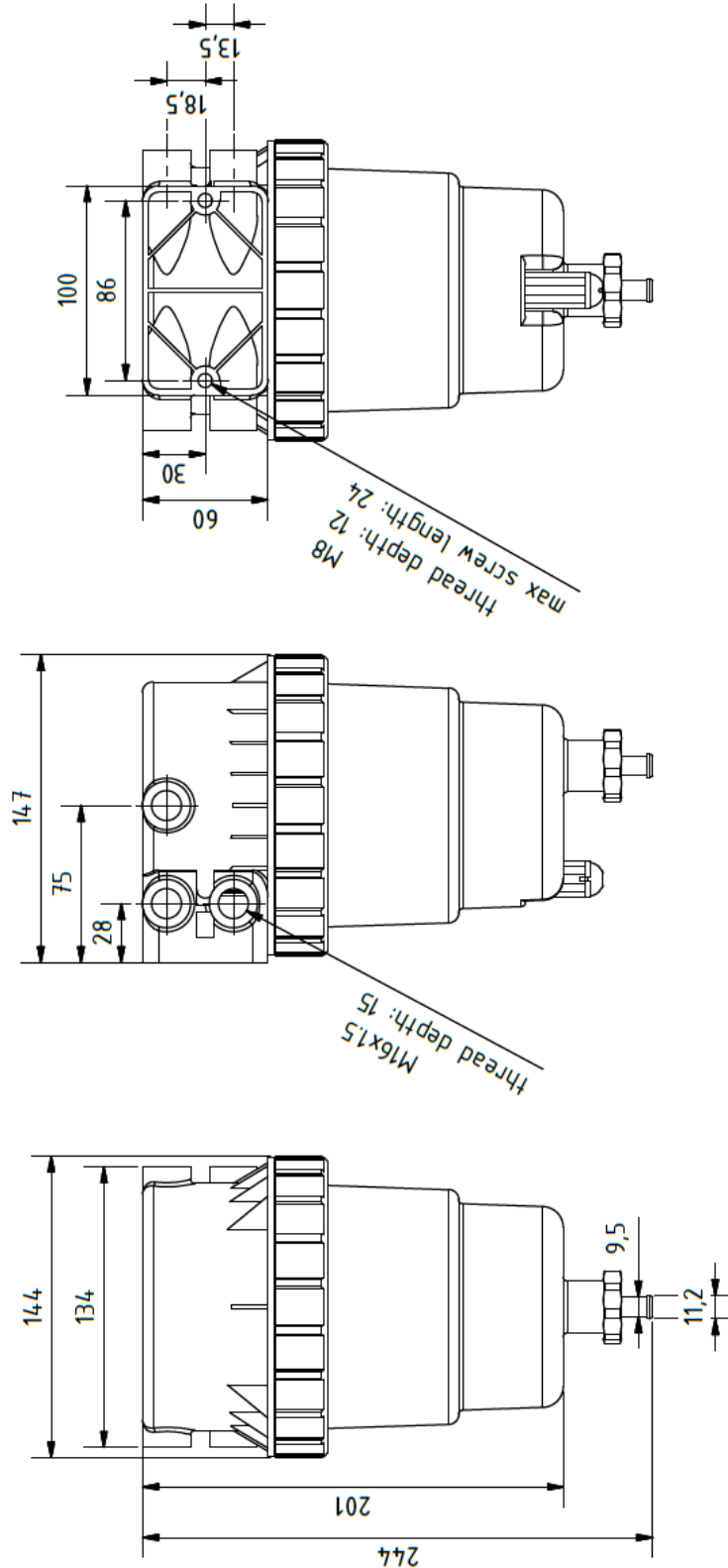

Label Assy. LKF-Industrial main dimensions		Project LKF-Industrial replacement for:		created by Texter		approval date	
general tolerances: undefined edges acc. to DIN ISO 2768-29 L to DIN ISO 13715 surface quality: DIN EN ISO 1302 meas. unit: in mm		Willibrord Lösing Filterproduktion GmbH Am Walzwerk 2 DE-45527 Hattingen www.loesing-filter.de		document type customer information		drawing no. Z31365-01-K101-EN-R00	
material: surface treatment: mass: 0,0 kg		replaced by:		part no. Z31365-01-K101-EN-R00		Rev. Rev.	
L1 L1		AL		T: 3		page 1 of 1	

Technical data LKF-Automotive

Areas of application	Diesel fuels, separation of water and fuel		
Flowrate		approx. 3 l/min	
Separation process	Water		Coalescence medium + hydrophobic water blocking
	Solid matter		Mechanical over filter medium and sedimentation upstream of the filter element
Filter surface area		approx. 8 dm ²	
Filter pore size		10 µm	Insert separately changeable
		6 µm	Insert separately changeable
Degree of water separation		> 95%	ISO/TS 16332
Differential pressure on the filter		< 50 mbar	At 3 l/min and 20°C fuel temperature Fuel according to EN 590
Dimensions	Width	approx. 110 mm	
	Depth	approx. 110 mm	
	Height	approx. 170 mm	
Necessary installation height	Height	approx. 240 mm	Including space for water drain and filter withdrawal
Weight	Metal design	< 1 kg	Aluminium
	Plastic design	< 0.5 kg	Glass-fibre-reinforced PA
Temperature ranges	Operation	-25 °C ... +70 °C	
	Storage	-25 °C ... +70 °C	
Fixing		2 x M8	Optional M8 bolts, internal screw-threads or link plates with 8.5 mm bore.
Pipe connections	Standard thread	6 x M14 x 1.5	
Fuel heating	Internal		Use of the waste heat from fuel return flow
	External (optional)		Separate, controlled fuel heater to 600 W
Water separation capacity		ca. 70 ml	
Water alarm at		ca. 60 ml	
Sensor technology (optional)	Water detection		Separate sensor
	Filter wear		Separate sensor
	Temperature monitor		Separate sensor

Willibrord Lösing Filterproduktion GmbH

W. Lösing Filterproduktion GmbH • Am Walzwerk 2 • 45527 Hattingen



Sketch: LKF-Automotive

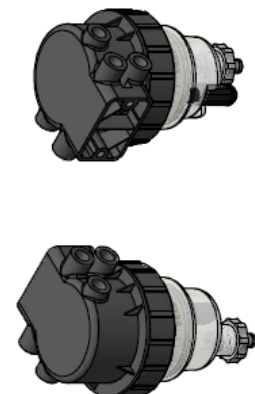
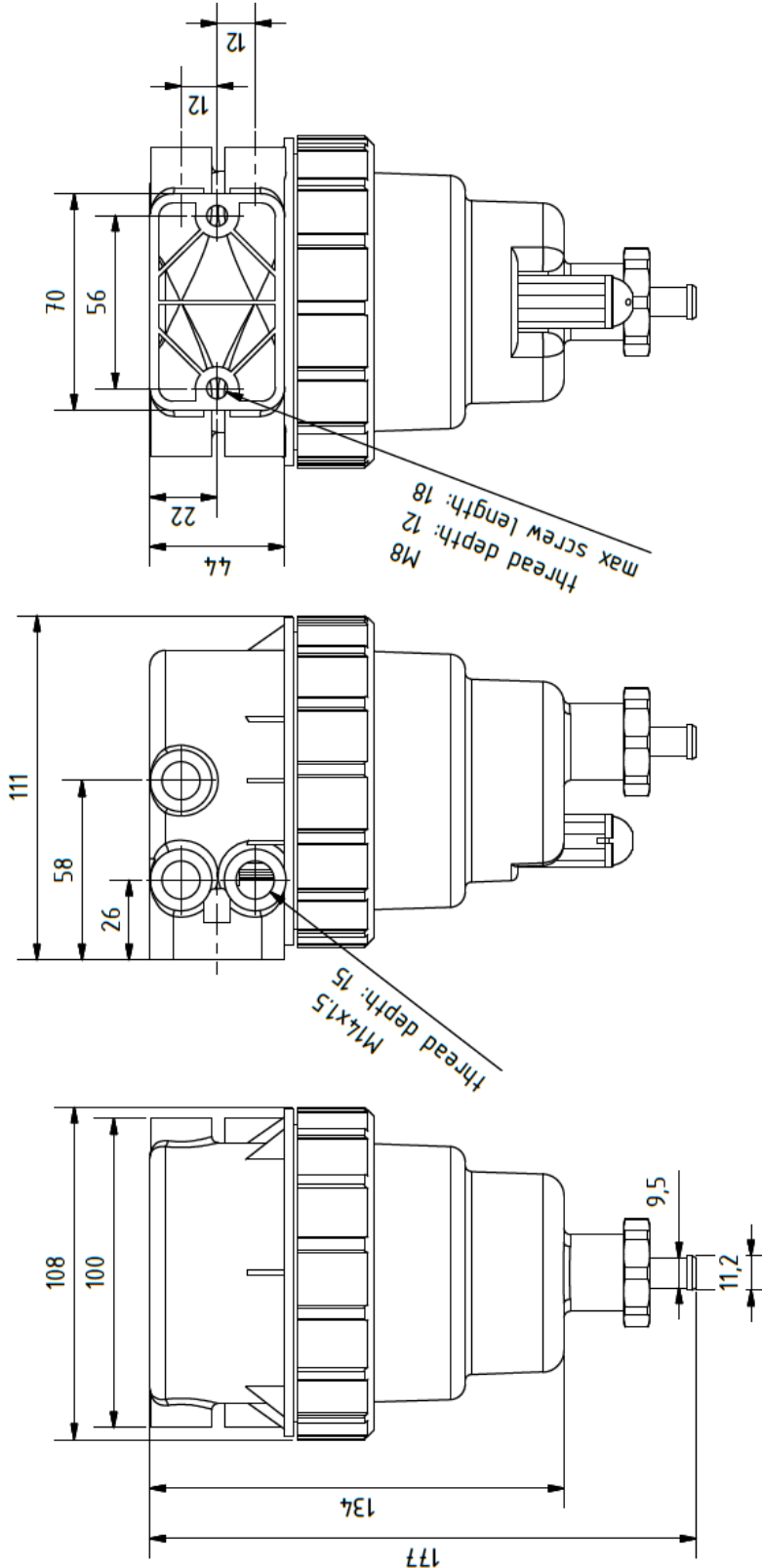

Label Assy. LKF-Automotive main dimensions		Project LKF-Automotive replacement for:		Created by Texter		Approval date	
General tolerances: undefined edges acc. to DIN ISO 2768 S-PL to DIN ISO 13715 Surface quality: DIN EN ISO 1302 meas. unit: in mm		Willibrord Lösing Filterproduktion GmbH Am Walzwerk 2 DE-45527 Hattingen www.loesing-filter.de		Document type customer information		Drawing no. Z31401-01-K101-EN-R01	
material surface treatment mass: 0,4 kg		Replaced by:		Part no. - opt. disctype lang. Rev.		1: 2 AL	
page 1 of 1							

Willibrord Lösing Filterproduktion GmbH

W. Lösing Filterproduktion GmbH • Am Walzwerk 2 • 45527 Hattingen



Functions: LKF-Industrial and LKF-Automotive

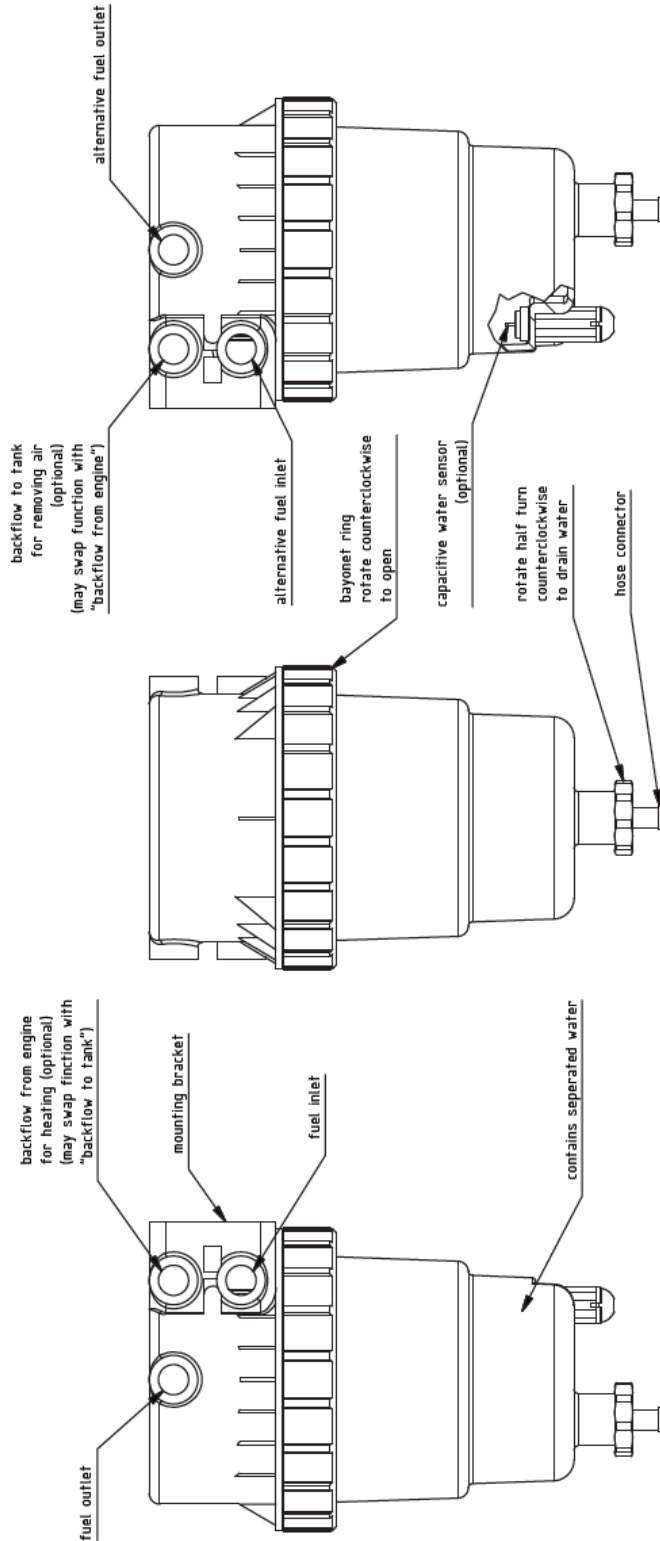

label Assy. LKF-Industrial functions		project LKF-Industrial replacement for:		created by Texter		approval date	
general tolerances DIN ISO 2768 mK		undefined edges acc. to DIN ISO 13715		document type customer information		drawing no. Z31365-01-K102-EN-R00	
surface quality DIN EN ISO 1302		material surface treatment		drawing no. Z31365-01-K102-EN-R00		part no. opt. disc.type lang. Rev.	
meas. unit: is. mm		mass: 0,8 kg		1: 3		AL	
replaced by:		Willibrord Lösing Filterproduktion GmbH Am Walzwerk 2 DE-45527 Hattingen www.loesing-filter.de		AL		page 1 of 1	